

# INDUSTRIAL THERMOMETER

The label *Trafag Industrial Components* extends the Trafag brand name to instruments manufactured by qualified partner companies.

*Trafag Industrial Components* complement the genuine Trafag product range to offer customers a complete portfolio from one single source.

The TMT702 Inert gas filled Industrial Thermometer is used in general industrial applications with extreme media temperatures from -200°C up to +700°C where an external zero setting is required.



## Applications

- Liquid & gaseous mediums
- Corrosive environments
- Oil & Gas applications
- Chemical & Petrochemical

### Features

- Inert gas filled expansion
- Filled versions
- Bi-metal compensation

### Reference

- EN 13190
- ATEX 2014/34/UE

07/2020

Data sheet H20020c

Standard parameters	
Accuracy	CL 1.0 (Class 1)
Permissible ambient temperature	-40 ... +60°C with/without dampening
Storage & Transport temperature	-50 ... +70°C without liquid dampening -20 ... +60°C with liquid dampening
Over range limits	110% full scale
Stem pressure rating	25 bar (Without thermowell)
Weld joints	TIG argon arc welding
Measuring range	-200 ... 0 to 0 ... 700°C -330 ... 0 to 0 ... 1290°F

## Ordering code

		TMT702 - XX - XXX - XX - XXX - XX - XXXX - XX - XX - XX - XX - XX - XXXX - XX			
<b>1. Dial size</b>	100 mm / 4"	<b>04</b>			
	125 mm / 4½"	<b>05</b>			
	150 mm / 6"	<b>06</b>			
	250 mm / 10"	<b>10</b>			
<b>2. Range<sup>1</sup></b>	Refer "Range Table" <sup>2</sup>		<b>XXX</b>		
<b>3. Mounting pattern</b>	Direct, Bottom connection	<b>B0</b>	Lower, Back connection <b>L0</b>		
	Wall/Surface/Projection mounting, Bottom connection	<b>B1</b>	Panel/Front flange mounting, Lower Back connection <b>L1</b>		
	2" Pipe/Yoke mounting, Bottom connection	<b>B2</b>	Panel/bracket mounting, Lower Back connection <b>L2</b>		
	Centre Back connection	<b>R0</b>			
	Every Angle mounting, Centre Back connection	<b>R1</b>			
<b>4. Stem diameter</b>	6,0 mm	<b>M60</b>	¼" (6,35 mm) <b>I14</b>		
	8,0 mm	<b>M80</b>	9,5 mm <b>M95</b>		
	10 mm	<b>M10</b>	12 mm <b>M12</b>		
<b>5. Ingress protection</b>	IP 65	<b>ER</b>	IP 67 <b>ET</b>		
	IP 66	<b>ES</b>			
<b>6. Stem length</b>	Up to 1,500 mm		<b>XXXX</b>		
<b>7. Process connection type</b>	Fixed connection	<b>KX</b>	Swivel / Revolving connection <b>BW</b>		
	Adjustable connection	<b>KW</b>	Without <b>99</b>		
<b>8. Process connection<sup>1</sup></b>	½" NPT (M)	<b>14N</b>	½" NPT (F) <b>04N</b>	3/8" BSP (M) <sup>6</sup> <b>13B</b>	Special <sup>1</sup> <b>ZZZ</b>
	¼" NPT (M) <sup>5</sup>	<b>12N</b>	M27 X 2.0 mm (M) <b>16M</b>	¾" BSP (M) <b>15B</b>	
	M20 X 1.5 mm (M)	<b>14M</b>	½" BSP (M) <b>14B</b>	¾" NPT (F) <b>05N</b>	
	¾" NPT (M)	<b>15N</b>	¼" BSP (M) <sup>5</sup> <b>12B</b>	Without <b>099</b>	
<b>9. Assembly</b>	Direct (Stem type)	<b>B8</b>	Remote (Capillary type) <sup>4</sup>	<b>B9</b>	
<b>10. Capillary</b>	AISI 304SS	<b>OU</b>	AISI 316 SS	<b>OV</b>	
<b>11. Armour</b>	AISI 304 SS			<b>OX</b>	
	AISI 316 SS			<b>OY</b>	
	PVC (Ambient max. 60°C)			<b>OZ</b>	
<b>12. Remote mounting length</b>	250 mm up to 25,000 mm		<b>XXXXX</b>		
<b>13. Other options</b>	Case & Ring in AISI 316 SS (B0) <sup>3</sup>	<b>BA</b>	Helium gas filled system	<b>E9</b>	SS tag plate, AISI 304 SS <b>XF</b>
	Case & Ring in AISI 316 SS (B1) <sup>3</sup>	<b>BB</b>	Shatterproof safety glass	<b>GC</b>	SS tag plate, AISI 316 SS <b>XG</b>
	Case & Ring in AISI 316 SS (B2) <sup>3</sup>	<b>BC</b>	Dampened movement	<b>GM</b>	Dial tag marking <b>XT</b>
	Case & Ring in AISI 316 SS (R0) <sup>3</sup>	<b>BG</b>	Maximum Reading pointer <sup>3</sup>	<b>GW</b>	Custom designed dial <b>XR</b>
	Case & Ring in AISI 316 SS (R1) <sup>3</sup>	<b>BH</b>	Dampening liquid, silicon oil	<b>OA</b>	Dampening liquid, glycerin (65°C) <b>EG</b>
	Case & Ring in AISI 316 SS (L0) <sup>3</sup>	<b>BK</b>	Rubber parts, Viton	<b>RA</b>	ATEX Version <sup>7</sup> <b>AX</b>
	Case & Ring in AISI 316 SS (L1) <sup>3</sup>	<b>BL</b>	5 - point calibration certificate	<b>TA</b>	
	Case & Ring in AISI 316 SS (L2) <sup>3</sup>	<b>BM</b>	Material test certificate 2.2	<b>TM</b>	

<sup>1</sup> For other ranges, connections, please contact factory.

<sup>2</sup> Equivalent scales available in °F, °C/°F, °F/°C.

<sup>3</sup> Option "Case & Ring in AISI 316 SS" is applicable for DN100 & DN150 only.

<sup>4</sup> While selecting capillary, Bottom connections are supplied with wall mounting flange & Back connection are with Panel / front flange.

<sup>5</sup> 1/4" connections are available up to 1/4" (6.35 mm) stem diameter only.

<sup>6</sup> 3/8" connections are available up to 10 mm stem diameter only.

<sup>7</sup>  2 G Ex h IIC T6÷T1 Gb X

II 2 D Ex h IIIC T85°C÷T450°C Db

Specifications			
<b>Material of construction</b>	Sensing element	Inert Gas Filled sensor bulb	
	Case & Ring material	AISI 304 SS	
	Stem & Process connection material	AISI 316 SS	
	Dial	Aluminum, black graduation on white background	
	Pointer	Micrometer zero adjustable, aluminum, black powder coated	
	Gaskets	NBR	
	Window	Sheet glass	
	<b>Standard specifications</b>	Dial size	DN100 / DN125 / DN150/DN250
Range		-200 ... 0 to 0 ... +700°C / -330 ... 0 to 0 ... +1290°F	
Mounting pattern		Direct Bottom connection	
Stem size		6,0 mm	
Ingress protection		IP 65	
Zero adjustment		External screw	
Stem length		70 mm to 2,000 mm*	
Process connection type		Adjustable connection	
Process connection		½" NPT (M) / ½" BSP (M)	
<b>Standard specifications : dampening liquid filled, glycerin</b>		Gaskets & Filling plugs	NBR
		Dampening liquid	Glycerin 99.7% (-20°C to 65°C) [Up to range 100°C]
	Window	Shatterproof safety glass	
<b>Standard specifications : dampening liquid filled, silicon</b>	Gaskets & Filling plugs	NBR	
	Dampening liquids	Silicon oil [Up to range 200°C]	
	Window	Shatterproof safety glass	
* Depending on range & stem diameter			

## Dimensions - All dimensions are in mm

Mounting pattern: B0

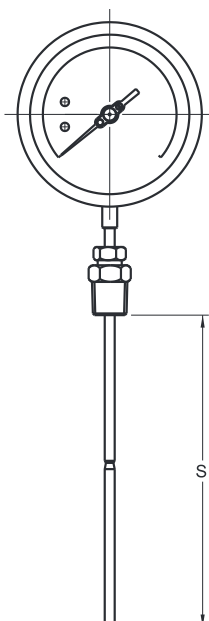
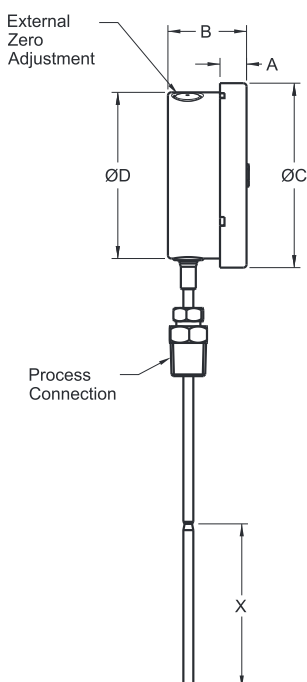

DN	A	B	ØC	ØD	S	X
100	12	48	111	100	*	**
125	15	48	129	118,5	*	**
150	15	48	161	149	*	**
250	18,5	50	263	250	*	**

\* As per customer requirement.  
 \*\* Refer Stem length chart table.

## Mounting pattern: B1

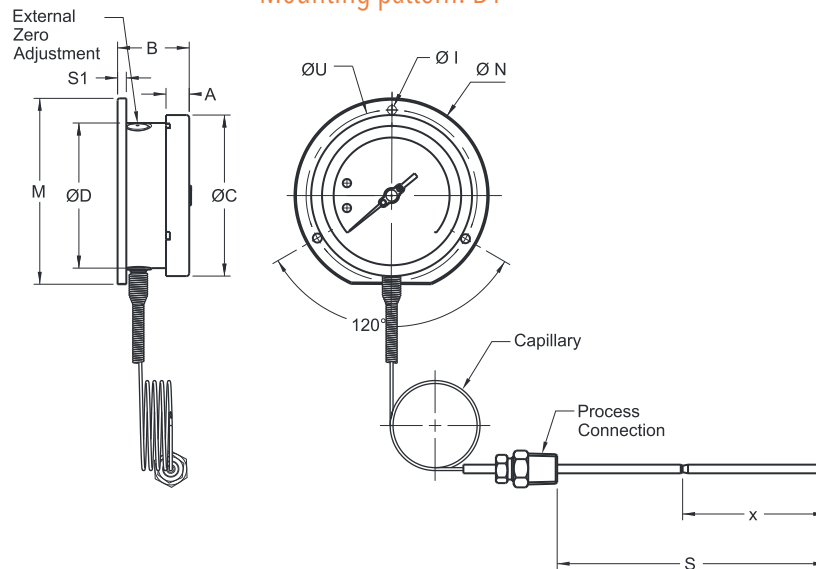

DN	A	B	ØC	ØD	ØI	ØN	M	S1	ØU	S	X
100	12	52	111	100	6	134	128	6	118	*	**
125	15	50	129	118.5	6	150	143,5	4	137	*	**
150	15	52	161	149	6	186	172,4	6	168	*	**
250	18.5	51.5	263	250	7	290	286.5	1,5	276	*	**

\* As per customer requirement.  
 \*\* Refer Stem length chart table.

## Mounting pattern: R0

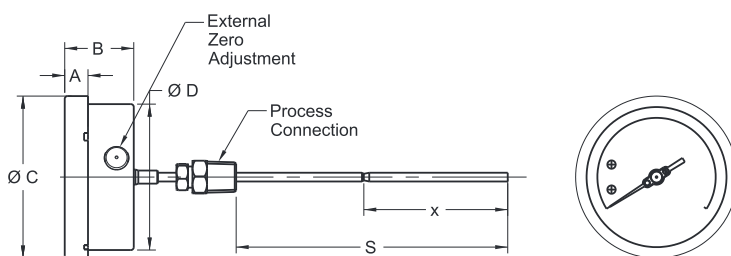

DN	A	B	ØC	ØD	S	X
100	12	48	111	100	*	**
125	15	48	129	118,5	*	**
150	15	48	161	149	*	**
250	18,5	50	263	250	*	**

\* As per customer requirement.  
 \*\* Refer Stem length chart table.

## Mounting pattern: R1

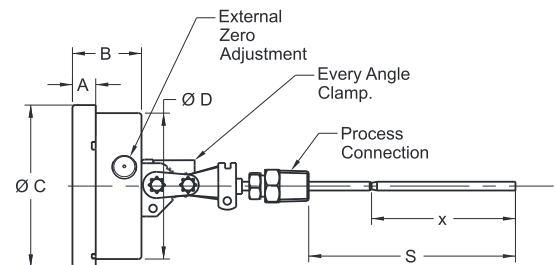

DN	A	B	ØC	ØD	S	X
100	12	48	111	100	*	**
125	15	48	129	118,5	*	**
150	15	48	161	149	*	**
250	18,5	50	263	250	*	**

\* As per customer requirement.  
 \*\* Refer Stem length chart table.

## Mounting pattern: L0

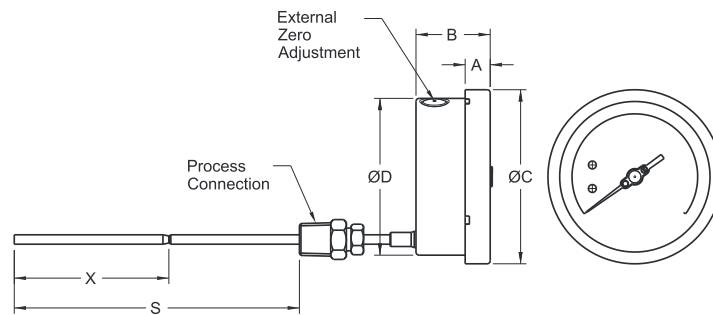

DN	A	B	ØC	ØD	S	X
100	12	48	111	100	*	**
125	15	48	129	118,5	*	**
150	15	48	161	149	*	**
250	18,5	50	263	250	*	**

## Mounting pattern: L1

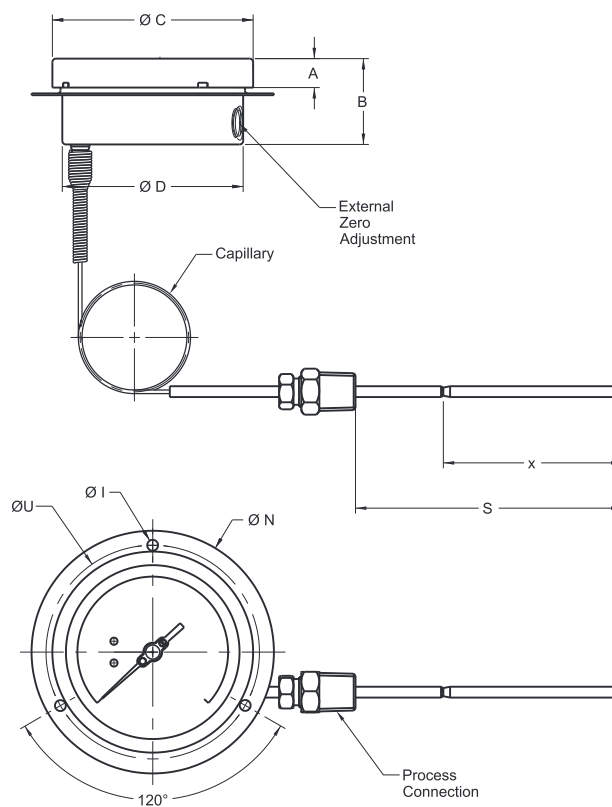

DN	A	B	ØC	ØD	ØI	ØN	ØU	S	X
100	12	48	111	100	6	134	118	*	**
125	15	48	129	118,5	6	150	137	*	**
150	15	48	161	149	6	186	168	*	**
250	18.5	50	263	250	7	290	276	*	**

\* As per customer requirement.  
 \*\* Refer Stem length chart table.

## Mounting pattern: L2

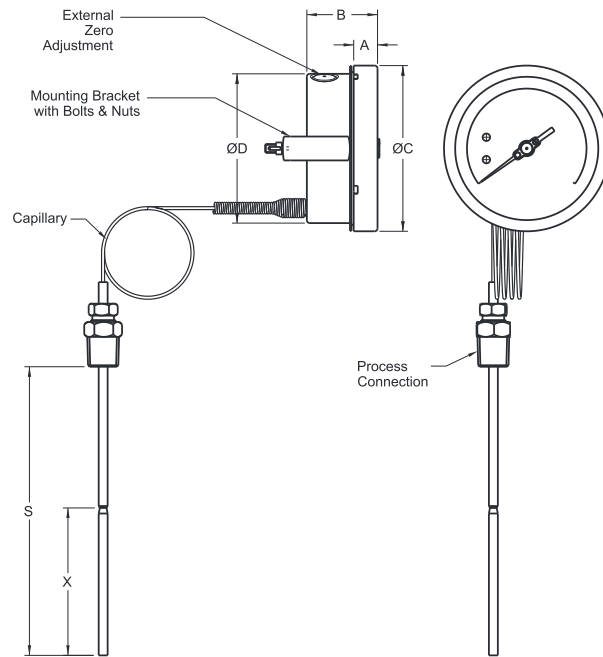

DN	A	B	ØC	ØD	J	K	V	S	X
100	12	48	111	100	72	16	108	*	**
125	15	48	129	118.5	75	15	125	*	**
150	15	48	161	149	106,5	16	158,5	*	**
250	18.5	50	263	250	180	30	270	*	**

\* As per customer requirement.  
 \*\* Refer Stem length chart table.

## Mounting pattern: B2

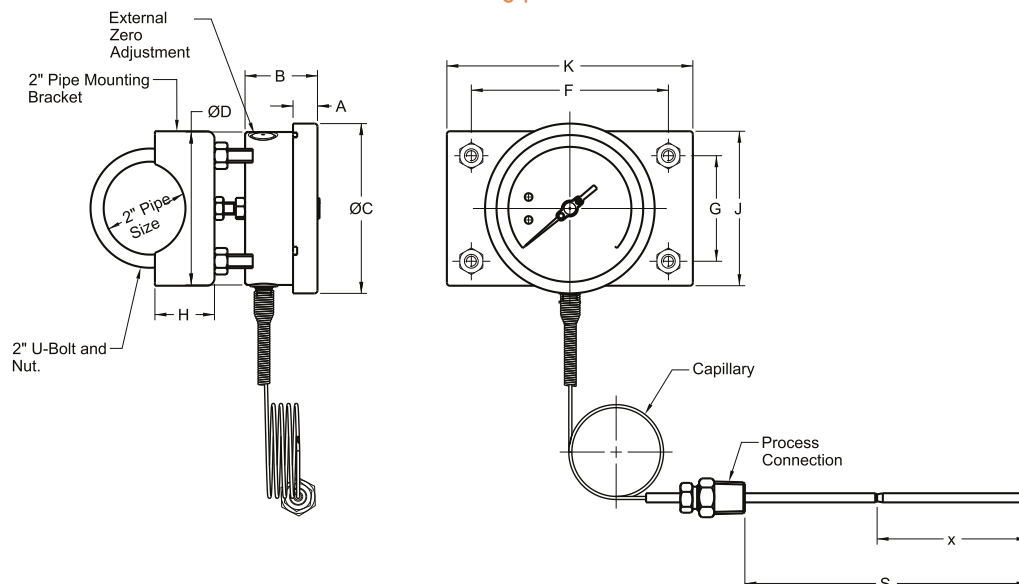

DN	A	B	ØC	ØD	S	X	F	G	H	J	K
100	12	48	111	100	*	**	129	69	39	101	161
125	15	48	129	118.5	*	**	129	69	39	101	161
150	15	48	161	149	*	**	129	69	39	101	161
250	18.5	50	263	250	*	**	129	69	39	101	161

\* As per customer requirement.

\*\* Refer Stem length chart table.

## Stem length chart

Stem/Sensor Size (mm)	(x) Sensor Length (mm)	(S) Minimum stem Length (mm)
<b>Rigid stem type Inert Gas Thermometer</b>		
<b>Capillary type Inert Gas Thermometer (<math>\leq 10</math> m)</b>		
6 / 1/4"	200	240
8 / 9,5	120	160
10	90	130
12/14	70	110
<b>Capillary type Inert Gas Thermometer (&gt;10 m up to 25 m)</b>		
8/9,5	170	210
10	140	180
12/14	90	130

- All length mentioned above are to be considered below thread only.
- For other reduced length, contact factory before ordering.

<sup>1)</sup> For other connections, please contact factory.

<sup>2)</sup> Equivalent scales available in °F, °C/°F, °F/°C. Please contact factory for details.

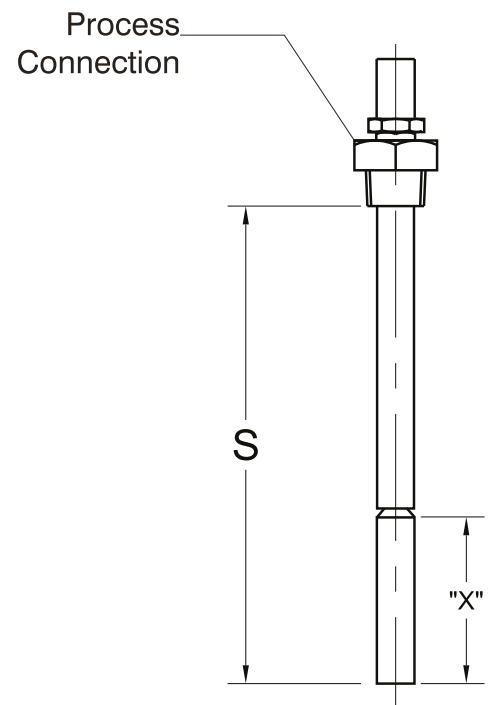

Range table (°C)	Code
-20 ... +40	C01
-20 ... +60	C02
-20 ... +80	C03
-20 ... +100	C04
-20 ... +120	C05
-20 ... +180	C06
-30 ... +50	C07
-30 ... +70	C08
-40 ... +40	C09
-40 ... +60	C10

Range table (°C)	Code
-50 ... +100	C11
-100 ... +60	C12
0 ... 50	C13
0 ... 60	C14
0 ... 80	C15
0 ... 100	C16
0 ... 120	C17
0 ... 150	C18
0 ... 160	C19
0 ... 200	C20

Range table (°C)	Code
0 ... 250	C21
0 ... 300	C22
0 ... 400	C23
0 ... 500	C24
0 ... 600	C25
0 ... 650	C26
50 ... 650	C27
100 ... 600	C28
100 ... 700	C29

### Additional information

Documents	Data sheet	H20020	<a href="http://www.trafag.com/H20020">www.trafag.com/H20020</a>
	Instructions	H21019	<a href="http://www.trafag.com/H21019">www.trafag.com/H21019</a>