



DIN 4754



IEC 61508

SIL



RoHS III
COMPLIANT



Operating manual

NK10

Fill Level Limiter

09005111 • BA_EN_NK10 • Rev. ST4-J • 12/22



Masthead

Manufacturer:
FISCHER Mess- und Regeltechnik GmbH

 Bielefelderstr. 37a
 D-32107 Bad Salzuflen

 Telephone: +49 5222 974 0
 Telefax: +49 5222 7170

 eMail: info@fischermesstechnik.de

 web: www.fischermesstechnik.de
Technical editorial team:

Documentation representative: T. Malischewski

Technical editor: R. Kleemann

All rights, also those to the translation, reserved. No part of this document may be reproduced or processed, duplicated or distributed using electronic systems or any other form (print, photocopy, microfilm or another process) without the written consent of the company FISCHER Mess- und Regeltechnik GmbH, Bad Salzuflen.

Reproduction for internal use is expressly allowed.

Brand names and procedures are used for information purposes only and do not take the respective patent situation into account. Great care was taken when compiling the texts and illustrations; Nevertheless, errors cannot be ruled out. The company FISCHER Mess- und Regeltechnik GmbH will not accept any legal responsibility or liability for this.

Subject to technical amendments.



© FISCHER Mess- und Regeltechnik 2015

Version history

Rev. ST4-A 01/15	Version 1 (first edition)
Rev. ST4-B 06/16	Version 2 (Correction)
Rev. ST4-C 04/17	Version 4 (Dimensional drawings changed)
Rev. ST4-D 11/18	Version 5 (Dimensional drawing/DNV-GL/CE declaration changed)
Rev. ST4-E 01/19	Version 6 (Order codes optional information (SIL))
Rev. ST4-F 12/20	Version 7 (New SIL certificate)
Rev. ST4-G 01/21	Version 8 (New DIN CERTCO certificate)
Rev. ST4-H 04/21	Version 9 (Corrections SIL)
Rev. ST4-J 12/22	Version 10 (certificates updated)

Table of Contents

1 Safety guidelines	4
1.1 General	4
1.2 Personnel Qualification	4
1.3 Risks due to Non-Observance of Safety Instructions	4
1.4 Safety Instructions for the Operating Company and the Operator	4
1.5 Unauthorised Modification	4
1.6 Inadmissible Modes of Operation	4
1.7 Safe working practices for maintenance and installation work	5
1.8 Pictogram explanation	5
2 Product and functional description	6
2.1 Delivery scope	6
2.2 Use as intended	6
2.3 Use in safety-related systems (SIL)	6
2.4 Function diagram	6
2.5 Design and mode of operation	7
3 Installation and assembly	8
3.1 Process connection	8
3.2 Electrical connections	8
4 Commissioning	9
4.1 Generalities	9
4.2 Function test	9
5 Servicing	10
5.1 Maintenance	10
5.2 Transport	10
5.3 Service	10
5.4 Disposal	10
6 Technical data	11
6.1 General	11
6.2 Application conditions	11
6.3 Switch contacts	11
6.4 Measurement accuracy	11
6.5 Directives and certificates	12
6.6 Construction design	13
7 Order Codes	18
8 Attachments	19
8.1 Declarations of conformity	19
8.2 Type testing certificates	20
8.3 DIN CERTCO Certification DIN 4754-3	26
8.4 SIL Certificate	28
8.5 EAC Declaration	30

1 Safety guidelines

1.1 General

This operating manual contains basic instructions for the installation, operation and maintenance of the device that must be followed without fail. It must be read by the installer, the operator and the responsible specialist personnel before installing and commissioning the device.

This operating manual is an integral part of the product and therefore needs to be kept close to the instrument in a place that is accessible at all times to the responsible personnel.

The following sections, in particular instructions about the assembly, commissioning and maintenance, contain important information, non-observance of which could pose a threat to humans, animals, the environment and property.

The instrument described in these operating instructions is designed and manufactured in line with the state of the art and good engineering practice.

1.2 Personnel Qualification

The instrument may only be installed and commissioned by specialized personnel familiar with the installation, commissioning and operation of this product.

Specialized personnel are persons who can assess the work they have been assigned and recognize potential dangers by virtue of their specialized training, their skills and experience and their knowledge of the pertinent standards.

1.3 Risks due to Non-Observance of Safety Instructions

Non-observance of these safety instructions, the intended use of the device or the limit values given in the technical specifications can be hazardous or cause harm to persons, the environment or the plant itself.

The supplier of the equipment will not be liable for damage claims if this should happen.

1.4 Safety Instructions for the Operating Company and the Operator

The safety instructions governing correct operation of the instrument must be observed. The operating company must make them available to the installation, maintenance, inspection and operating personnel.

Dangers arising from electrical components, energy discharged by the medium, escaping medium and incorrect installation of the device must be eliminated. See the information in the applicable national and international regulations.

Please observe the information about certification and approvals in the Technical Data section.

1.5 Unauthorised Modification

Modifications of or other technical alterations to the instrument by the customer are not permitted. This also applies to replacement parts. Only the manufacturer is authorised to make any modifications or changes.

1.6 Inadmissible Modes of Operation

The operational safety of this instrument can only be guaranteed if it is used as intended. The instrument model must be suitable for the medium used in the system. The limit values given in the technical data may not be exceeded.

The manufacturer is not liable for damage resulting from improper or incorrect use.

1.7 Safe working practices for maintenance and installation work

The safety instructions given in this operating manual, any nationally applicable regulations on accident prevention and any of the operating company's internal work, operating and safety guidelines must be observed.

The operating company is responsible for ensuring that all required maintenance, inspection and installation work is carried out by qualified specialized personnel.

1.8 Pictogram explanation



DANGER

Type and source of danger

This indicates a **direct** dangerous situation that could lead to death or **serious injury** (highest danger level).

1. Avoid danger by observing the valid safety regulations.



WARNING

Type and source of danger

This indicates a **potentially** dangerous situation that could lead to death or **serious injury** (medium danger level).

1. Avoid danger by observing the valid safety regulations.



CAUTION

Type and source of danger

This indicates a **potentially** dangerous situation that could lead to slight or serious injury, damage or **environmental pollution** (low danger level).

1. Avoid danger by observing the valid safety regulations.



NOTICE

Note / advice

This indicates useful information of advice for efficient and smooth operation.

2 Product and functional description

2.1 Delivery scope

- NK10 according to specification (see order code)
- Operating Manual
- Safety manual for SIL version

2.2 Use as intended

The NK10 fill level limiter is used in thermo-technical and process plants as a safeguard against the fill level falling below the lowest permissible level. As a limiter the device conforms to the requirements of DIN 4754.

The devices in this series are...

- type-tested in compliance with DIN 4754-3
- certified to DNVGL-CG-0339
- Functional safety as per IEC 61508
- certified to directive 2014/68/EU

Copies of the certificates can be found in the appendix to the operating manual.

2.3 Use in safety-related systems (SIL)

The unit can be used in safety-related systems.

For use in safety-related systems according to 'Functional Safety' (SIL), the correct function of the safety function must be proven. The necessary key figures, safety instructions, assembly and maintenance instructions can be found in the Safety Manual (SHB).

The safety manual is available for download at www.fischermesstechnik.de.



IEC 61508 SIL

2.4 Function diagram

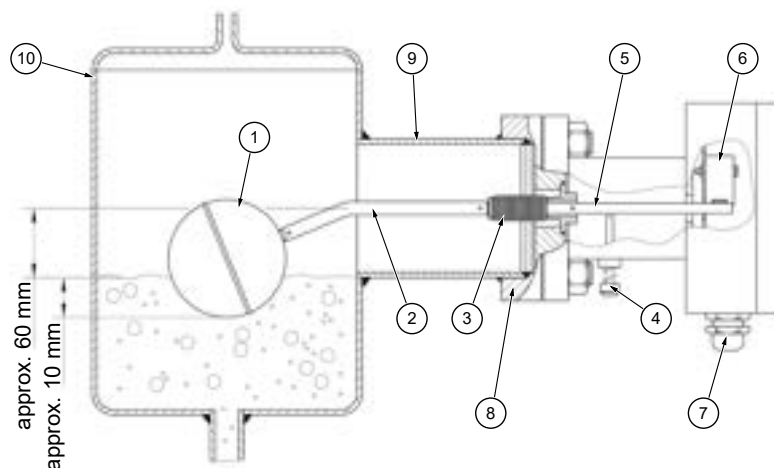

Fig. 1: Function diagram

1	Swimmer	2	Swimmer rod
3	Metal bellows	4	Test button
5	Switch lever	6	Micro-switch S1
7	Cable screw connection	8	Flange and counter-flange
9	Welding socket	10	Tank

2.5 Design and mode of operation

The swim system of the fill level limiter is contained in the fluid-filled reservoir (expansion tank). The swimming motions generated by changes in the fill level are transmitted directly to the micro-switch S1 by a swimmer rod sealed in a stainless-steel bellows. The fulcrum of the swimmer rod is located outside of the pressure chamber.

There is also a test button outside the pressure chamber with which a function check as per DIN 4754-3 can be run without lowering the fill level. When pressed, the body of the swimmer is moved against its buoyancy.

The factory default switching point of micro-switch S1 is set so that it switches when the swimmer rod is horizontal. The optional warning switch S2 switches approx. 2.5 mm before S1.

The fill level height at which switching is triggered depends on the density of the heat carrier. The lowest density at which a secure function is guaranteed is 0.6 kg/dm³.

When the medium has a density of 1.0 kg/dm³, the switching level is approx. 60mm below the middle of the flange or socket.

3 Installation and assembly

NOTICE! The information in the safety manual must be observed in connection with equipment with functional safety.

3.1 Process connection

The process connection may be realised by authorized and qualified specialized personnel.

The unit is set ex-works for horizontal installation. Only this installation position is allowed.

Dangers caused by pressure on the instrument are to be prevented with suitable measures.

The flange and/or process connections are designed for a working temperature of max. 400 °C and a working pressure of max. 20 bar.



CAUTION

The data of the flange used may be lower.

Please check the actual data in the technical data section.

There are a range of flanges and welded hexagon nipples with which the device can be installed on-site. Take care that the side of the device marked **TOP** faces upwards when being installed.

NOTICE! Please check:

- The swimmer must be able to move freely in the vertical direction!
- Test the switching function using the test button.

3.2 Electrical connections

- By authorized and qualified specialized personnel only.
- When connecting the unit, the national and international electro-technical regulations must be observed.
- Disconnect the system from the mains, before electrically connecting the device.
- Install the consumer-adapted fuses.
- Do not connect the connector if strained.

When laying the electrical supply lines, ensure that no short circuit between the electrical conductors and the surroundings can occur.

A locking and unlocking system as per DIN 4754-3 must be incorporated, if the device is used as a fill level limiter. This safety system must conform to DIN 50156 / VDDE 0116.

3.2.1 Circuit diagram

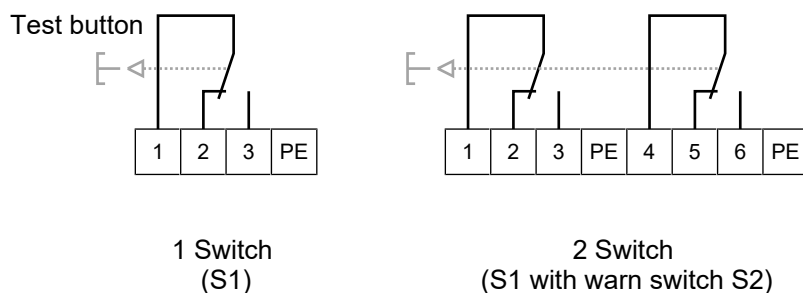

Fig. 2: Circuit diagram

4 Commissioning

4.1 Generalities

All electrical supply, operating and measuring lines and the pressure connections must have been correctly installed before starting operation and the flange connections must have been correctly made. All supply lines are arranged so that there are no mechanical forces acting on the device.

NOTICE! Leak test

The leak tightness of the flange connection must be tested in the course of the system leak tests.

4.2 Function test

There is a test button outside the pressure chamber with which a function check as per DIN 4754-3 can be made without lowering the fill level. When pressed, the body of the swimmer is moved against its buoyancy.

The factory default switching point of switch S1 (clamps 1, 2, 3) is set so that it switches when the swimmer rod is horizontal. The optional warning switch S2 switches ca. 2.5 mm before S1.

Check the function of the unit:

- Check the switching function (with the aid of the test button) in combination with the following components.
- Check the swimmer via the buoyancy behaviour after pressing the test button.

If the result of the function test is negative, the fill level limiter must be taken out of operation and the process must be kept safe by other means.

5 Servicing

5.1 Maintenance

CAUTION! Observe the system safety and operating regulations.

The instrument is maintenance-free. However, to ensure the device's reliable operation and long service life, we recommend regularly inspecting the device for the following points:

- Check the switching function (with the aid of the test button) in combination with the following components.
- Check the seal tightness of the flange connection.
- Check the electrical connections (cable clamp connection).

The test must be carried out once a year or more frequently depending on the operating regulations and must be documented in writing.

The exact test cycles need to be adapted to the operating and environmental conditions. If several components of the unit interact, all operating instructions of the other units also need to be observed.

All defective or faulty devices should be sent directly to our repair department. Please coordinate all shipments with our sales department. Return the device in the original packaging or a suitable transport container.

5.2 Transport

The measuring device must be protected against impacts. It should be transported in the original packaging or a suitable transport container.

5.3 Service

All defective or faulty devices should be sent directly to our repair department. Please coordinate all shipments with our sales department.



WARNING

Process media residues

Process media residues in and on dismantled devices can be a hazard to people, animals and the environment. Take adequate preventive measures. If required, the devices must be cleaned thoroughly.

Return the device in the original packaging or a suitable transport container.

5.4 Disposal

Please help to protect the environment by always disposing of the work pieces and packaging materials in compliance with the valid national waste and recycling guidelines or reuse them.

6 Technical data

6.1 General

Please also observe the order code here.

6.2 Application conditions

Ambient temperature	-10 ... +70 °C
Storage temperature	-20 ... +85 °C
Max. temperature of medium	Depends on model
Specific minimum density of medium	$\rho = 0.6 \text{ kg/dm}^3$
Installation position	horizontal
Type of protection	IP 55 acc. to DIN EN 60529

Variant	Max. working pressure:	Max. temperature of medium
NK10 1 ...	20 bar	400°C
NK10 2 ...	20 bar	400°C
NK10 3 ...	10 bar	350°C
NK10 4 ...	16 bar	400°C
NK10 5 ...	16 bar	400°C
NK10 6 ...	20 bar	400°C
NK10 7 ...	20 bar	400°C
NK10 A ...	10 bar	350°C
NK10 B ...	20 bar	400°C
NK10 F ...	20 bar	400°C
NK10 G ...	20 bar	400°C
NK10 H ...	20 bar	400°C
NK10 K ...	150 lbs	400°C
NK10 M ...	300 lbs	400°C
NK10 N ...	300 lbs	400°C
NK10 P ...	300 lbs	400°C

6.3 Switch contacts

Maximum load data at ohmic load.

250 V AC	6A
250 V DC	250 mA

6.4 Measurement accuracy

Switch hysteresis	approx. 6 mm
Switching point differential between S1 and S2 ⁽⁺⁾	max. 30 mm
Switching point differential on the medium surface	dependent on medium density

⁽⁺⁾ only for two micro-switches

6.5 Directives and certificates

Directives	Applied standards
Pressure Equipment Directive 2014/68/EU	DIN EN 13445-1:2021-12 DIN 4754-3:2015-03
Low Voltage Directive 2014/35/EU	DIN EN 61010-1:2020-03
RoHS Directive 2011/65/EU	DIN EN IEC 63000:2019-05

Approval	Certificate no.
EC type examination according to Pressure Equipment Directive (Module B)	0045/202/1403/Z/01261/22/D/001(00)
Conformity with the type related to the production process (module D/D1)	0045/202/1404/Z/00289/21/D/001(01)
DNV type examination	TAA000020S
DIN CERTCO acc. to 4754-3	10F001
Functional safety according to EN 61508 ^{*)}	968/V 1298.00/22

^{*)} Only for units with the order code for SIL (optional information).

6.6 Construction design

Swimmer system	Stainless steel 1.4571
Metal bellows	Stainless steel 1.4571
Flange / counter-flange (*)	Stainless steel 1.0425 (P265GH) or 1.4571
Welding socket	St.35.8 [1.0345 (P235GH)]
Screws / nuts (x)	G 7258 / C35PbK

(*) Please note the material information in the dimensional drawings.

(x) Only for version with welding connection

6.6.1 Dimensional drawings

All dimensions in mm unless otherwise stated

6.6.1.1 Version with welding connection

Version	Flange material		A	B	C [Ø]	D [square]	e
NK104	1.0425	P265GH	213	359	82.5	77.8 x 77.8	107
NK105	1.0425	P265GH	250	396	88.9	90.0 x 90.0	105

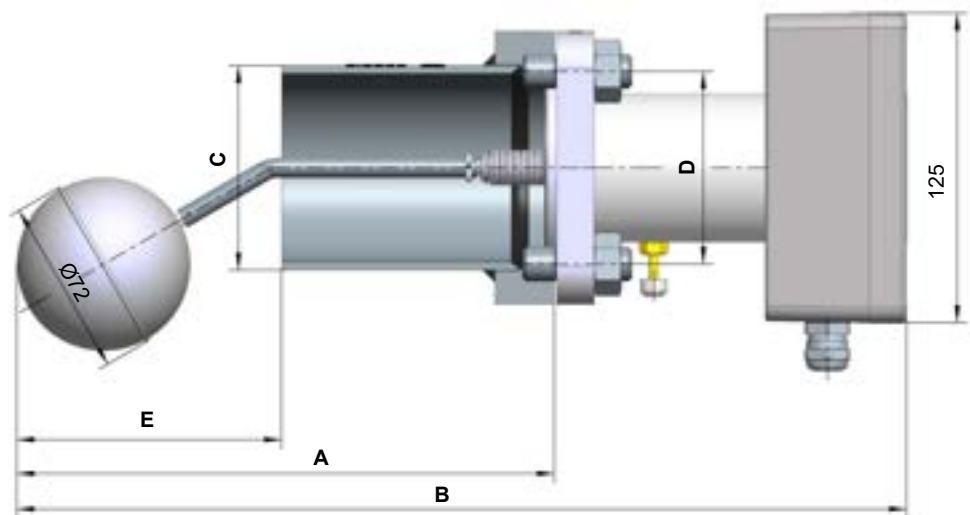

Fig. 3: Dimensional picture NK104 NK105

6.6.1.2 Flange DIN EN 1092-1 Type B1

Version	Flange material		Port	D [Ø]	LK [Ø]	B	b	d [Ø]	No. of holes
NK102	1.0425	P265GH	DN80 PN40	200	160	24	22	18	8
NK10G	1.4571	---	DN80 PN40	200	160	24	22	18	8

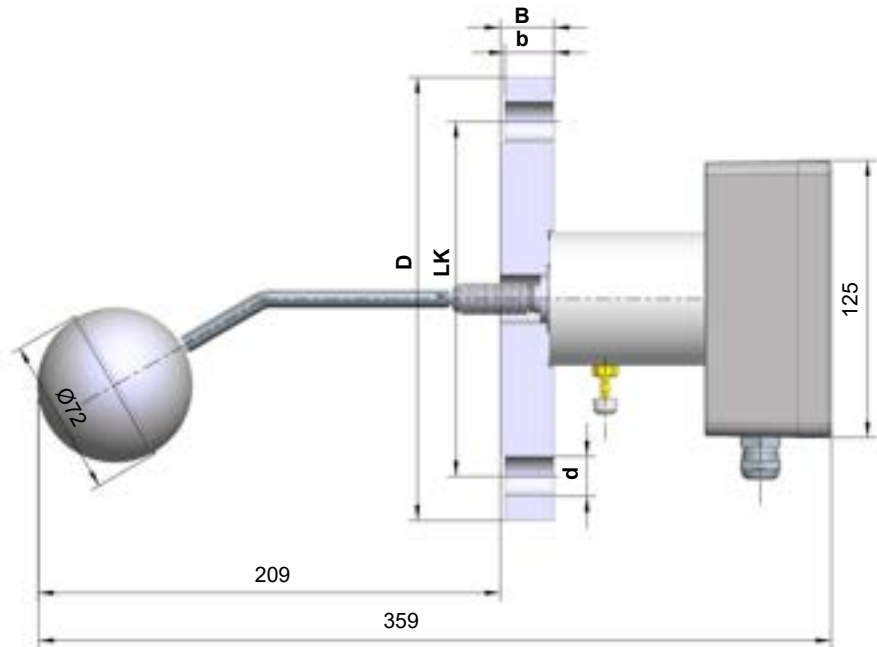

Fig. 4: Dimensional picture NK102 NK10G

Version	Flange material		Port	A	D [Ø]	LK [Ø]	B	b	d [Ø]	No. of holes
NK101	1.0425	P265GH	DN65 PN40	230	185	145	22	20	18	8
NK103	1.0425	P265GH	DN65 PN16	234	185	145	18	16	18	4
NK107	1.4571	---	DN65 PN40	230	185	145	22	20	18	8

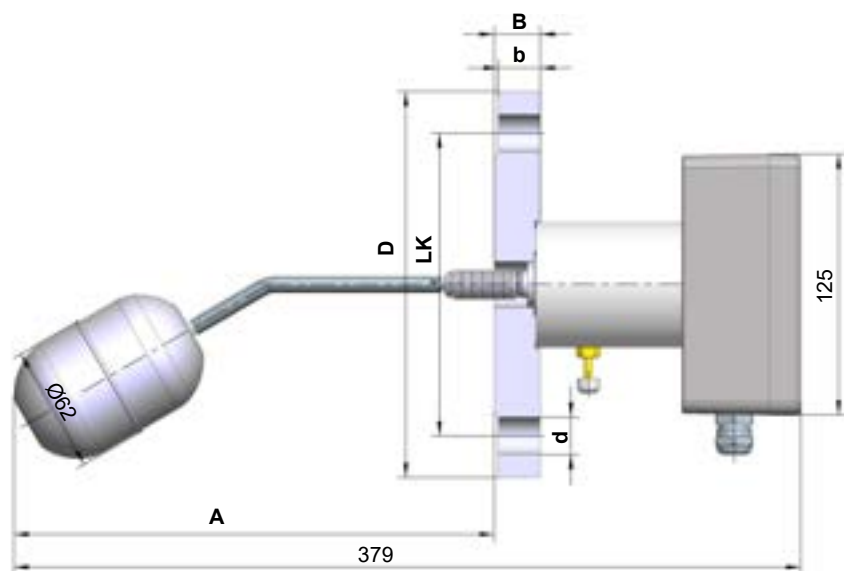

Fig. 5: Dimensional picture NK101 NK103 NK107

6.6.1.3 Flange DIN EN 1092-1 Type C

Version	Flange material	Port	D [Ø]	LK [Ø]	B	b	d [Ø]	No. of holes
NK10F	1.0425 P265GH	DN80 PN40	200	160	24	19.5	18	8

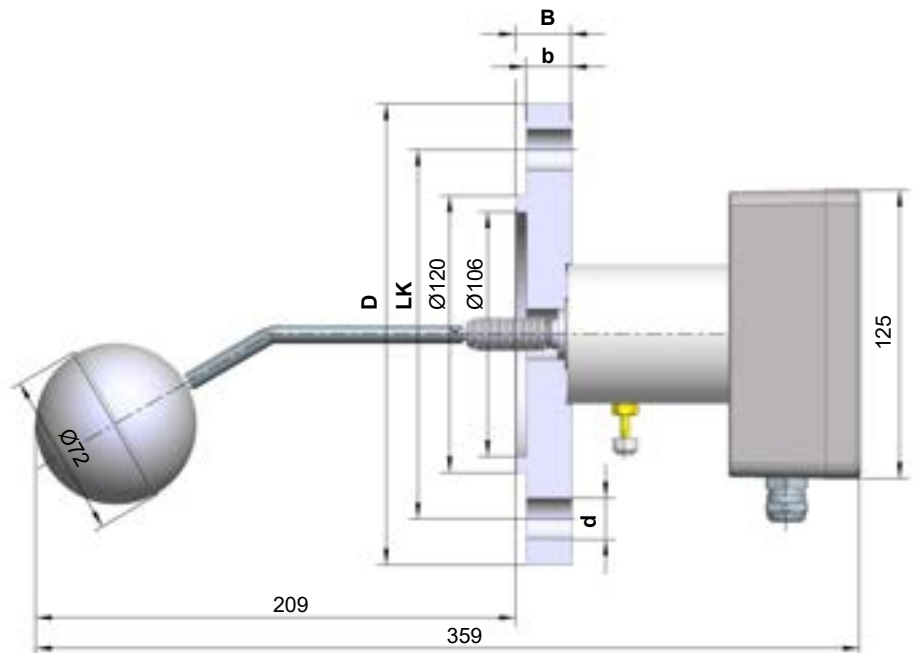

Fig. 6: Dimensional picture NK10F

Version	Flange material	Port	A	D [Ø]	LK [Ø]	B	b	d [Ø]	No. of holes
NK106	1.0425 P265GH	DN65 PN40	230	185	145	22	17.5	18	8
NK10A	1.0425 P265GH	DN65 PN16	234	185	145	18	13.5	18	4

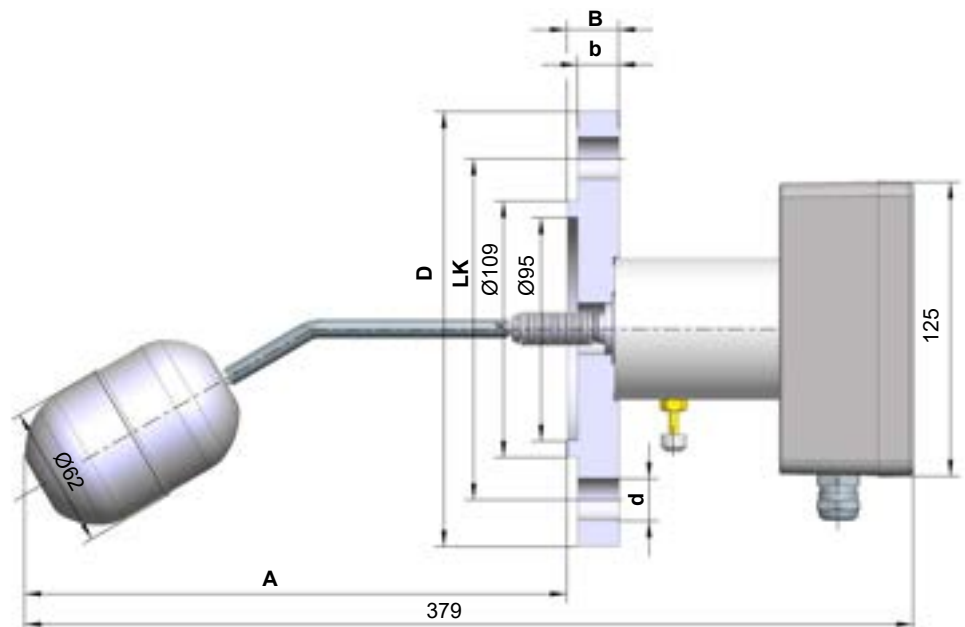

Fig. 7: Dimensional picture NK106 NK10A

6.6.1.4 Flange DIN EN 1092-1 Type G

Version	Flange material	Port	D [Ø]	LK [Ø]	B	b	d [Ø]	No. of holes
NK10H	1.4571 ---	DN80 PN40	200	160	24	22	18	8

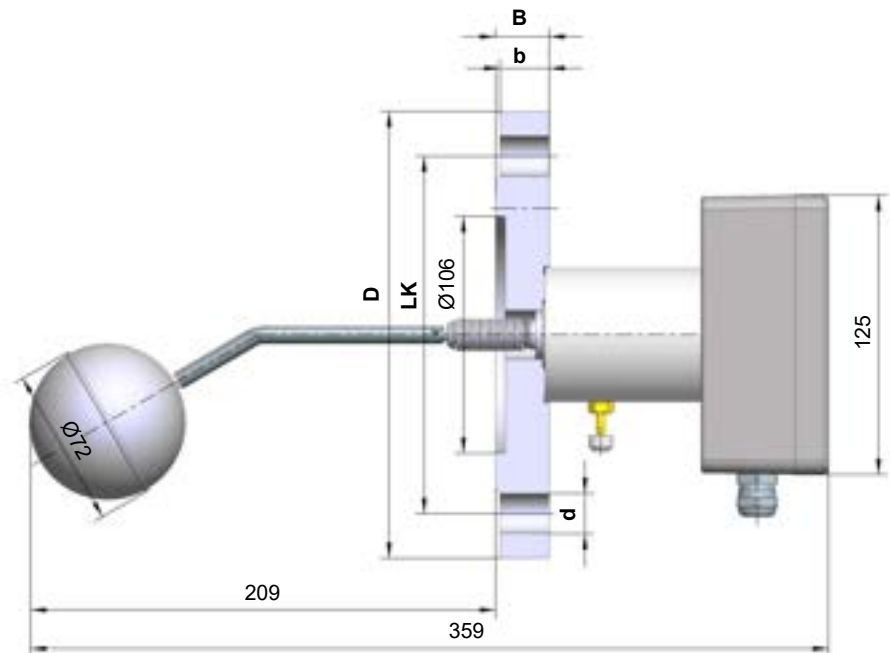

Fig. 8: Dimensional picture NK10H

6.6.1.5 Flange DIN EN 1092-1 Type D

Version	Flange material	Port	D [Ø]	LK [Ø]	B	b	d [Ø]	No. of holes
NK10B	1.0425 P265GH	DN65 PN40	185	145	22	20	18	8

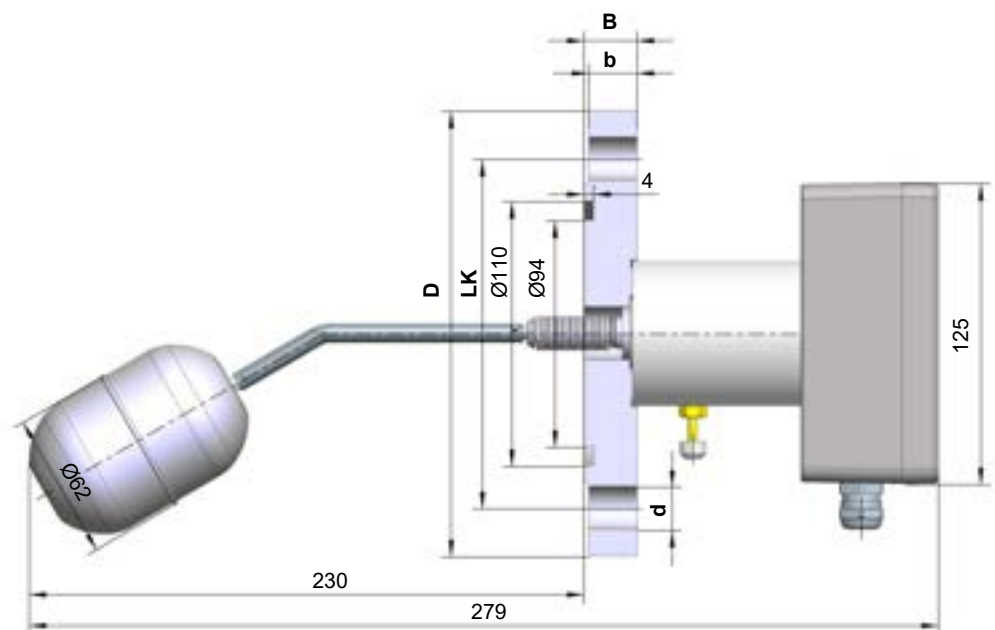

Fig. 9: Dimensional picture NK10B

6.6.1.6 Flange ANSI B16.5

Version	Flange material	Port	A	D [Ø]	LK [Ø]	B	b	d [Ø]	No. of holes
NK10K	1.0425 P265GH	3" 150 lbs	209	192.5	152.4	24	22.8	19.1	4
NK10N	1.0425 P265GH	3" 300 lbs	204	209.5	168.1	28.4	26.8	22.3	8
NK10P	1.0425 P265GH	4" 300 lbs	201	254	200.1	31.7	30.1	22.3	8

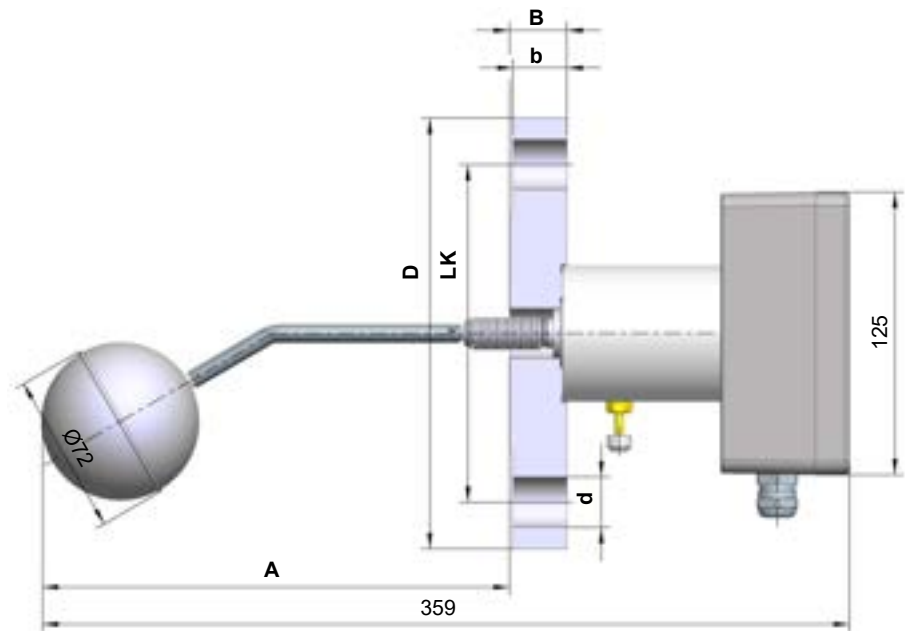

Fig. 10: Dimensional picture NK10K NK10N NK10P

Version	Flange material	Port	A	D [Ø]	LK [Ø]	B	b	d [Ø]	No. of holes
NK10M	1.0425 P265GH	2.5" 300 lbs	227	190.5	149.3	25.4	23.8	22.3	8

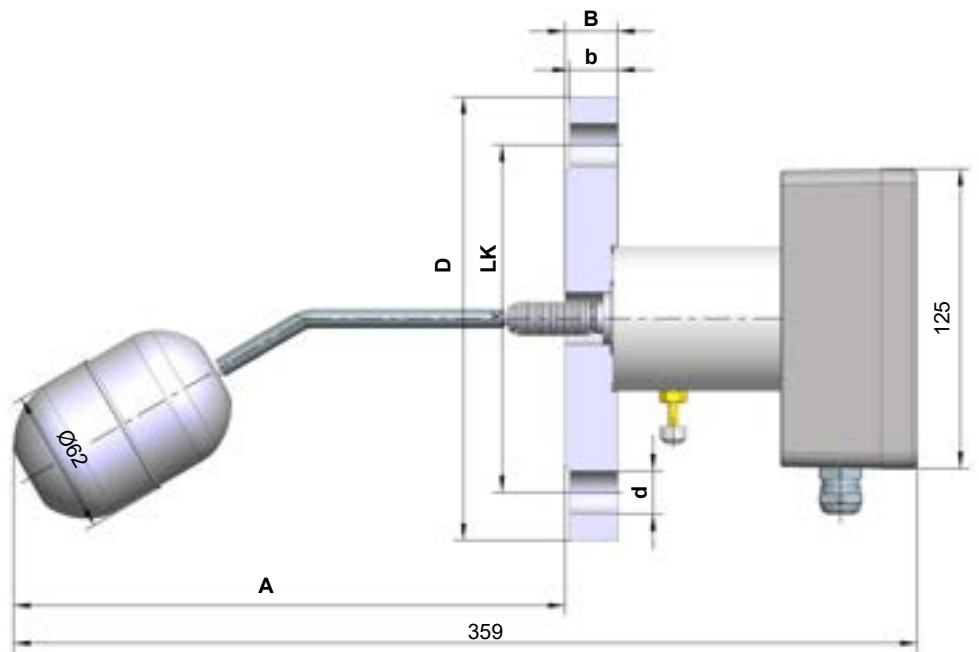
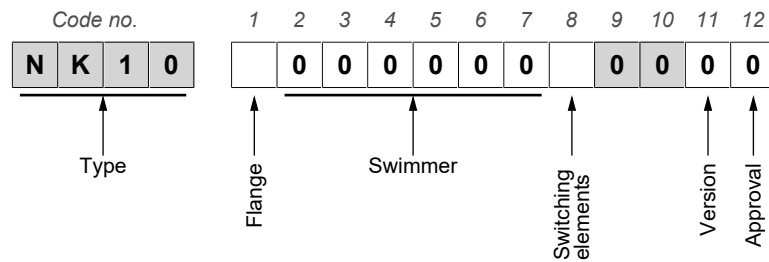

Fig. 11: Dimensional picture NK10M

7 Order Codes



[1]	Flange	material			
1	DIN EN 1092-1 Form B1	DN 65 PN40	1.0425	P265GH	
2	DIN EN 1092-1 Form B1	DN 80 PN40	1.0425	P265GH	
3	DIN EN 1092-1 Form B1	DN 65 PN16	1.0425	P265GH	
7	DIN EN 1092-1 Form B1	DN 65 PN40	1.4571	---	
g	DIN EN 1092-1 Form B1	DN 80 PN40	1.4571	---	
6	DIN EN 1092-1 Form C	DN 65 PN40	1.0425	P265GH	
A	DIN EN 1092-1 Form C	DN 65 PN16	1.0425	P265GH	
F	DIN EN 1092-1 Form C	DN 80 PN40	1.0425	P265GH	
B	DIN EN 1092-1 Form D	DN 65 PN40	1.0425	P265GH	
h	DIN EN 1092-1 Form G	DN 80 PN40	1.4571	---	

K	ANSI B16.5	3" 150 lbs	1.0425	P265GH
C	ANSI B16.5	2.5" 300 lbs	1.0425	P265GH
N	ANSI B16.5	3" 300 lbs	1.0425	P265GH
P	ANSI B16.5	4" 300 lbs	1.0425	P265GH

4	Welding connection	82.5 mm (S80)
5	Welding connection	88.9 mm (S90)

[2-7]	Swimmer
000000	Standard swimmer
#####	Special design on request

[8]	Switching Elements
1	1 micro-switch
2	2 micro-switch

[11]	Version
0	Standard
S	SIL

[12]	Approval
0	Standard unit with switching contacts (built-in microswitches)

8 Attachments

8.1 Declarations of conformity

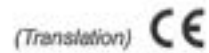

EU Declaration of Conformity

For the product described as follows

Product designation Level limiter
Type designation NK10

It is hereby declared that it corresponds with the basic requirements specified in the following designated directives:

2014/35/EU	Low Voltage Directive
2014/68/EU	Pressure Equipment Directive
2011/65/EU	RoHS Directive
(EU) 2015/863	Delegated Directive amending Annex II to Directive 2011/65/EU

The products were tested in compliance with the following standards.

DIN EN 61010-1:2020-03 EN 61010-1:2010 + A1:2019 + A1:2019/ AC:2019	Low Voltage Directive (LVD) Safety requirements for electrical equipment for measurement, control, and laboratory use - Part 1: General requirements
DIN EN 13445-1:2021-12 EN 13445-1:2021	Pressure Equipment Directive (PED) Unfired pressure vessels - Part 1: General
DIN EN IEC 63000:2019-05 EN IEC 63000:2018	RoHS Directive (RoHS3) Technical documentation for the assessment of electrical and electronic products with respect to the restriction of hazardous substances

Further applied technical specifications (not published in the Official Journal of the European Union):

DIN 4754-3:2015-03	Heat transfer installations working with organic heat transfer fluids - Part 1: Safety requirements
---------------------------	---

The notified body for the Pressure Equipment Directive
TÜV NORD SYSTEM GmbH & Co. KG
NB 0045

has issued the following certificates:

Equipment part for use in a safety chain as a complete equipment part with category IV safety function: 0045/202/1403/Z01261/22/D/001/00)	EC type examination 2014/68/EU (module B)
--	---

Manufacturer FISCHER Mess- und Regeltechnik GmbH
 Bielefelder Str. 37a
 32107 Bad Salzufflen, Germany
 Tel. +49 (0)5222 974 0

Documentation representative Torsten Malischewski
 General Manager R&D

The devices are marked with: **CE**

Bad Salzufflen
03 Jan 2023
 T. Malischewski
 General Manager R&D



Fig. 12: CE_EN_NK10

8.2 Type testing certificates

8.2.1 Pressurised Vessel Directive 2014/68/EU



ZERTIFIKAT CERTIFICATE

**EU-Baumusterprüfbescheinigung (Baumuster) - Modul B -
nach Richtlinie 2014/68/EU**
EU type-examination certificate (production type) - module B -
according to directive 2014/68/EU

Zertifikat-Nr.: 0045/202/1403/Z/01261/22/D/001(00)
Certificate No.:

Name und Anschrift des Herstellers: FISCHER Mess- und Regeltechnik GmbH
Name and address of manufacturer: Bielefelder Straße 37a
32107 Bad Salzuffen

Hiermit wird bescheinigt, dass das unten genannte Baumuster die Anforderungen der Richtlinie 2014/68/EU erfüllt.
We hereby certify that the type examination mentioned below fulfils the requirements of directive 2014/68/EU.

Prüfgrundlage: Test specification:	AD 2000
Prüfbericht-Nr.: Test report No.:	0045/202/1403/P/01261/D/22/001(00)
Beschreibung des Baumusters (Druckgerät): Description of production type (pressure equipment):	Füllstandsbegrenzer Typ NK 10 Baureihen.: NK101, NK 102, NK103, NK 104, NK105, NK106, NK 107, NK 10A, NK 10B, NK 10F, NK10G, NK10H, NK 10K, NK10M, NK10N, NP10P
Fertigungsstätte Place of manufacture:	FISCHER Mess- und Regeltechnik GmbH Bielefelder Straße 37a 32107 Bad Salzuffen
Gültig bis: Valid until:	08/2032

Anlagen:
Attachment



Notifizierte Stelle 0045 für Druckgeräte
Notified Body 0045 for pressure equipment



Digital unterschrieben
von Kocielnik Bodo
Datum: 2022.12.13
15:34:37 +01'00'

TUV NORD Systems GmbH & Co. KG, Große Bahnstraße 2H, 22525 Hamburg

Kontakt / Contact:
E-Mail: imrnhgebietest@tuv-nord.de
Tel./Phone: +49 (0) 231/5186-0

Zur Verifizierung der Gültigkeit eines digital signierten Dokuments ist die Installation des TÜV NORD-GROUP Stammzertifikats notwendig: <https://www.tuv-nord.de>, unter Kunden Login/Digitale Signature
To verify the validity of a digitally signed document, an installation of the TÜV NORD GROUP root certificate is required: <https://www.tuv-nord.de/2022/02/20220220>, with Customer Login/Digital Signature

© EU Baumuster Druckgerät und Baugruppe des eng digital Rev. 1:18.20

Fig. 13: 8120501655 Type certificate NK 10 - 2022

8.2.2 DNV GL Certificate



Certificate No:
TAA000020S

TYPE APPROVAL CERTIFICATE

This is to certify:
That the Level Switches

with type designation(s)
NK10

Issued to
FISCHER Mess- und Regeltechnik GmbH
Bad Salzufflen, Nordrhein-Westfalen, Germany

is found to comply with
DNV GL rules for classification – Ships, offshore units, and high speed and light craft

Application :
Product(s) approved by this certificate is/are accepted for installation on all vessels classed by DNV GL.

Location classes:

Temperature	B (-20 °C / 16h)
Humidity	B
Vibration	A
EMC	N/A
Enclosure	B (IP 55)

Issued at **Hamburg** on **2018-09-26**

This Certificate is valid until **2023-09-25**.
 DNV GL local station: **Magdeburg**

Approval Engineer: **Holger Jansen**



Digitally Signed By: **Rinkel, Marco**
 for **DNV GL**
 Location: Hamburg, on behalf of

Joannis Papanuskas
Head of Section

This Certificate is subject to terms and conditions overleaf. Any significant change in design or construction may render this Certificate invalid. The validity date relates to the Type Approval Certificate and not to the approval of equipment/systems installed.

Form code: TA 251

Revision: 2016-12

www.dnvgl.com

Page 1 of 3

© DNV GL 2014. DNV GL and the Horizon Graphic are trademarks of DNV GL AS.

Fig. 15: DNVGL_TAA000020S_Page_1

Job Id: **262.1-029690-1**
 Certificate No: **TAA000020S**

Product description

Type: NK10

Float switch with functional tset facility

Temperature medium: max. 400 °C (depending on the type)

Nominal pressure: max. 20 bar (depending on the type)

Output: 1 or 2 c/o – contact(s), rating 6 A, 250 Vac

Material float: 1.4571

Material flange: 1.4571 / 1.0425 (P265GH)

Material welding tube: P235GH TC1

Order code: NK10x000000y0000

Type NK101: flange DIN EN 1092-1 form B1 DN65 PN40 1.0425
 Type NK102: flange DIN EN 1092-1 form B1 DN80 PN40 1.0425
 Type NK103: flange DIN EN 1092-1 form B1 DN80 PN16 1.0425
 Type NK104: 82,5 mm welding tube (S80)
 Type NK105: 88,9 mm welding tube (S90)
 Type NK106: flange DIN EN 1092-1 form C DN65 PN40 1.0425
 Type NK107: flange DIN EN 1092-1 form B1 DN65 PN40 1.4571
 Type NK10A: flange DIN EN 1092-1 form C DN65 PN16 1.0425
 Type NK10B: flange DIN EN 1092-1 form D DN65 PN40 1.0425
 Type NK10F: flange DIN EN 1092-1 form C DN40 PN40 1.0425
 Type NK10G: flange DIN EN 1092-1 form B1 DN80 PN40 1.4571
 Type NK10H: flange DIN EN 1092-1 form G DN80 PN40 1.4571
 Type NK10K: flange - 3" - ANSI B16.5 - 150lbs - 1.0425
 Type NK10M: flange - 2,5" - ANSI B16.5 - 300lbs - 1.0425
 Type NK10N: flange - 3" - ANSI B16.5 - 300lbs - 1.0425
 Type NK10P: flange - 4" - ANSI B16.5 - 300lbs - 1.0425

y = 1: 1 c/o contact

y = 2: 2 c/o contacts

Application/Limitation

The Type Approval covers hardware listed under Product description. When the hardware is used in applications to be classed by DNV GL, documentation for the actual application is to be submitted for approval by the manufacturer of the application system in each case. Reference is made to DNV GL rules for classification of ships Pt.4 Ch.9 Control and Monitoring Systems.

Type Approval documentation

Data Sheet 09005238 Rev. A 06/13

Operating instruction 09005016 Rev. A 06/13

Drawing no. 07.010.00.21403.2 Rev. b, 2012-08-21; no. 07.010.00.20458.2 Rev. b, 2012-08-21;

no. 07.010.02.00030.V Rev. a, 2009-09-30

Part list no. 07.010.02.00088.V, 2012-11-19; no. 07.010.02.00030.V, 2012-05-14

Test report: paconsult no. 13-5195, 2013-07-25;

Fischer no. 02.010.03.35896.V, 2013-08-26; no. 07.010.02.00030.V Rev. a 2009-09-30

Type Approval Assessment Report 2018-08-28

Fig. 16: DNVGL_TAA000020S_Page_2

Job Id: **262.1-029690-1**
Certificate No: **TAA000020S**

Tests carried out

Applicable tests according to Class Guideline DNVGL-CG-0339, Edition November 2016.

Marking of product

The products to be marked with:

- manufacturer name
- type name
- serial number

Periodical assessment

The scope of the periodical assessment is to verify that the conditions stipulated for the type are complied with, and that no alterations are made to the product design or choice of systems, software versions, components and/or materials.

The main elements of the assessment are:

- Ensure that type approved documentation is available
- Inspection of factory samples, selected at random from the production line (where practicable)
- Review of production and inspection routines, including test records from product sample tests and control routines
- Ensuring that systems, software versions, components and/or materials used comply with type approved documents and/or referenced system, software, component and material specifications
- Review of possible changes in design of systems, software versions, components, materials and/or performance, and make sure that such changes do not affect the type approval given
- Ensuring traceability between manufacturer's product type marking and the type approval certificate

Periodical assessment is to be performed after 2 years and after 3.5 years. A renewal assessment will be performed at renewal of the certificate.

END OF CERTIFICATE

Fig. 17: DNVGL_TAA000020S_Page_3

8.3 DIN CERTCO Certification DIN 4754-3



CERTIFICATE

Certificate holder	FISCHER Mess- und Regeltechnik GmbH Bielefelder Str. 37a 32107 Bad Salzuffen GERMANY
Product	Flow switches for heat transfer installations
Type, Model	NK10...
Testing basis	DIN 4754-3:2015-03 Zertifizierungsprogramm Strömungs- und Füllstandsicherungen (2016-01)
Mark of conformity	
Registration No.	10F001
Valid until	2025-10-31
Right of use	This certificate entitles the holder to use the mark of conformity shown above in conjunction with the specified registration number. See annex for further information.



2020-12-21 

Dipl.-Wi.-Ing. (FH) Sören Scholz
Head of Certification Body

DIN CERTCO Gesellschaft für Konformitätsbewertung mbH · Alboinstraße 56 · D-12103 Berlin · www.dinertco.de

Fig. 18: DIN_CERTCO_10F001_EN_Page_1



ANNEX

Page 1 of 1

Certificate	10F001 dated 2020-12-21
Technical Data	Measuring device: float system Transfer of measured values: values: mechanically by float rod with bellow Operating pressure: 6 bar, 10 bar and 16 bar (according to design) Ambient temperature: -10 °C to +70 °C Medium temperature: 350 °C and +400 °C (according to design) Rated voltage: 250 V AC, 5 A and DC 30 V, 0,4 A Installation position: horizontal
Testing laboratory/ Inspection body	TÜV Rheinland Industrie Service GmbH Am Grauen Stein 51105 Köln GERMANY
Test report(s)	FBW 1810/15 dated 2015-10-07 968/FI 1018.00/18 dated 2018-09-24 968/FI 1018.01/19 dated 2019-09-27968/FSP 2160.00/20 von 2020-11-25



8.4 SIL Certificate

Certificate





SIL/PL
Capability

www.tuv.com
ID 000000000

Nr./No.: 968/V 1298.00/22

Prüfgegenstand Product tested	Füllstandsbegrenzer Level Limiter	Zertifikats- inhaber Certificate holder	Fischer Mess- und Regeltechnik GmbH Bielefelder Str. 37a 32107 Bad Salzuflen Germany
Typbezeichnung Type designation	NK10 / NK10 H		
Prüfgrundlagen Codes and standards	IEC 61508 Parts 1-2 and 4-7:2010		
Bestimmungsgemäße Verwendung Intended application	<p>Sicherheitsfunktion 1: Sicheres Schalten bei Erreichen des eingestellten Grenzwertes (Schalter S1)</p> <p>Sicherheitsfunktion 2: Sichere Vorwarnung bei Erreichen des eingestellten Grenzwertes (Schalter S2) - Option</p> <p>Die Füllstandsbegrenzer sind zur Verwendung in einem sicherheitsgerichteten System bis SIL 2 geeignet. Unter Berücksichtigung der mindestens erforderlichen Hardware-Fehlertoleranz von HFT = 1 können die Armaturen in redundanter Ausführung auch bis SIL 3 eingesetzt werden.</p> <p>Safety function 1: safe switching when the set limit value is reached (switch S1)</p> <p>Safety function 2: safe pre-warning when the set limit value is reached (switch S2) - option.</p> <p>The level limiter are suitable for use in a safety instrumented system up to SIL 2. Under consideration of the minimum required hardware fault tolerance HFT = 1 the valves may be used in a redundant architecture up to SIL 3.</p>		
Besondere Bedingungen Specific requirements	<p>Die Hinweise in der zugehörigen Installations- und Betriebsanleitung sowie des Sicherheitshandbuchs sind zu beachten.</p> <p>The instructions of the associated installation, Operating and Safety Manual shall be considered.</p>		
<p>Zusammenfassung der Testergebnisse siehe Seite 2 des Zertifikates. Summary of test results see page 2 of this certificate.</p>			
<p>Der Ausstellung dieses Zertifikates liegt eine Evaluierung entsprechend dem Zertifizierungsprogramm CERT FSP1 V1.0:2017 in der aktuellen Version zugrunde, deren Ergebnisse im Bericht Nr. 968/V 1298.00/22 vom 08.08.2022 dokumentiert sind. Dieses Zertifikat ist nur gültig für Erzeugnisse, die mit dem Prüfgegenstand übereinstimmen.</p> <p>The issue of this certificate is based upon an evaluation in accordance with the Certification Program CERT FSP1 V1.0:2017 in its actual version, whose results are documented in Report No. 968/V 1298.00/22 dated 2022-08-08. This certificate is valid only for products, which are identical with the product tested.</p>			

TÜV Rheinland Industrie Service GmbH

Bereich Automation
Funktionale Sicherheit



Dipl.-Ing. (FH) Wolf Rückwart

Köln, 2022-08-11 Certificates by Safety & Security (FS) Division & Grid

00222_12_12 E 44 © TÜV. TÜV and TÜV are registered trademarks. Utilization and application requires prior approval.

 TÜV Rheinland Industrie Service GmbH, Am Graues Stein, 51158 Köln / Germany
Tel.: +49 221 808-1790, Fax: +49 221 808-1038, E-Mail: industrie-service@tuv.com

www.fs-products.com
www.tuv.com



Fig. 20: 968_V_1298_00_22_de_en_el_page_1

968/V 1298.00/22 - page 2



Holder: Fischer Mess- und Regeltechnik GmbH
 Bielefelder Straße 37a
 D-32107 Bad Salzuffen
 Germany

Product tested: Level indicator / level limiter
 NK10 / NK10 H

Results of Assessment

Route of Assessment		$2_{s1} / 1_{s2}$
Type of Sub-system		Type A
Mode of Operation		Low Demand Mode
Hardware Fault Tolerance	HFT	0
Systematic Capability		SC 3

Safe switching when the set limit value is reached (switch S1)

Dangerous Failure Rate	λ_0	3.13 E-07 / h	313 FIT
Average Probability of Failure on Demand 1001	$PFD_{avg}(T_1)$	1.39 E-03	
Average Probability of Failure on Demand 1002	$PFD_{avg}(T_1)$	1.41 E-04	

Safe prewarning when the set limit value is reached (switch S2) - option

Dangerous Failure Rate	λ_0	3.13 E-07 / h	313 FIT
Average Probability of Failure on Demand 1001	$PFD_{avg}(T_1)$	1.39 E-03	
Average Probability of Failure on Demand 1002	$PFD_{avg}(T_1)$	1.41 E-04	

Assumptions for the calculations above: DC = 0 %, $T_1 = 1$ year, MRT = 72 h, $\beta_{1002} = 10$ %

High Demand Mode

In the opinion of the testing laboratory, the failure rates determined for the low demand mode can also be used for high demand mode applications up to a maximum demand rate of $n_{req} = 12 / a$. No failures due to wear are to be expected.

Origin of failure rates

The stated failure rates for low demand are the result of an FMEDA with tailored failure rates for the design and manufacturing process.

Furthermore the results have been verified by qualification tests and field-feedback data.

Failure rates include failures that occur at a random point in time and are due to degradation mechanisms such as ageing.

The stated failure rates do not release the end-user from collecting and evaluating application-specific reliability data.

Periodic Tests and Maintenance

The given values require periodic tests and maintenance as described in the Safety Manual.

The operator is responsible for the consideration of specific external conditions (e.g. ensuring of required quality of media, max. temperature, time of impact), and adequate test cycles.

Fig. 21: 968_V_1298_00_22_de_en_el_page_2

8.5 EAC Declaration



**ЕВРАЗИЙСКИЙ ЭКОНОМИЧЕСКИЙ СОЮЗ
ДЕКЛАРАЦИЯ О СООТВЕТСТВИИ**



Заявитель Общество с ограниченной ответственностью "МАТИС-М"

Место нахождения: Россия, Москва, 117261, улица Вавилова, дом 70, строение 3, Комната Правления,
адрес места осуществления деятельности: Россия, Москва, 109029, Сибирский проезд, дом 2, строение
9, офис 58, основной государственный регистрационный номер: 1037739575125, номер телефона:
+74957252304, адрес электронной почты: info@matis-m.ru

в лице Генерального директора Шарова Александра Анатольевича

заявляет, что Ограничитель уровня серии НК

изготовитель "Fischer Mess- und Regeltechnik GmbH". Место нахождения и адрес места
осуществления деятельности по изготовлению продукции: Bielefelder Straße 37a, D-32107 Bad
Salzuflen, Германия.

Продукция изготовлена в соответствии с Директивой 2014/35/EU.
Код ТН ВЭД ЕАЭС 9026108900. Серийный выпуск

соответствует требованиям

Технического регламента Таможенного союза "О безопасности низковольтного оборудования" (ТР ТС
004/2011)

Декларация о соответствии принята на основании

Протокола испытаний № 0104-ИЛ23/2022 от 28.01.2022 года, выданного Испытательной лабораторией
Общества с ограниченной ответственностью «ПромМашЭксперт», аттестат аккредитации РОСС
RU.32001.04ИБФ1.ИЛ23, сроком действия до 02.02.2022 года.

Схема декларирования Id

Дополнительная информация

Условия и сроки хранения стандартные при нормальных значениях климатических факторов внешней
среды, срок службы (годности) указан в эксплуатационной документации. Договор на выполнение
функций иностранного изготовителя № 2016-09-29/01 от 29.09.2016.

Декларация о соответствии действительна с даты регистрации по 27.01.2027 включительно

(подпись)

 М. Д.
 Шаров Александр Анатольевич
(Ф.И.О. заявителя)

Регистрационный номер декларации о соответствии: ЕАЭС N RU Д-DE.PA01.B.46596/22

Дата регистрации декларации о соответствии: 28.01.2022

Fig. 22: EAC_RU_NK

Notes



FISCHER Mess- und Regeltechnik GmbH

Bielefelder Str. 37a
D-32107 Bad Salzuflen

Tel. +49 5222 974-0

Fax +49 5222 7170

www.fischermesstechnik.de
info@fischermesstechnik.de