

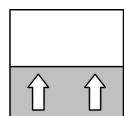

Data sheet

NC56

Capacitive filling level probe



1 Product and functional description

1.1 Performance characteristics

Typical applications

Measurement of tank filling levels for

- fresh water
- Waste water, faeces
- Diesel fuel
- Extinguishing foam

Areas of application

- Procedural technology
- Process technology
- Environmental technology
- Vehicle technology
- Ship technology

Main features

- Robust design (IP67)
- Easy start-up
- Reliable use
- The probe can be used regardless of the tank material (metal, plastic or concrete) and the shape of the tank.
- Variable installation dimensions between 400 and 2000 mm in 50 mm steps

1.2 Device versions

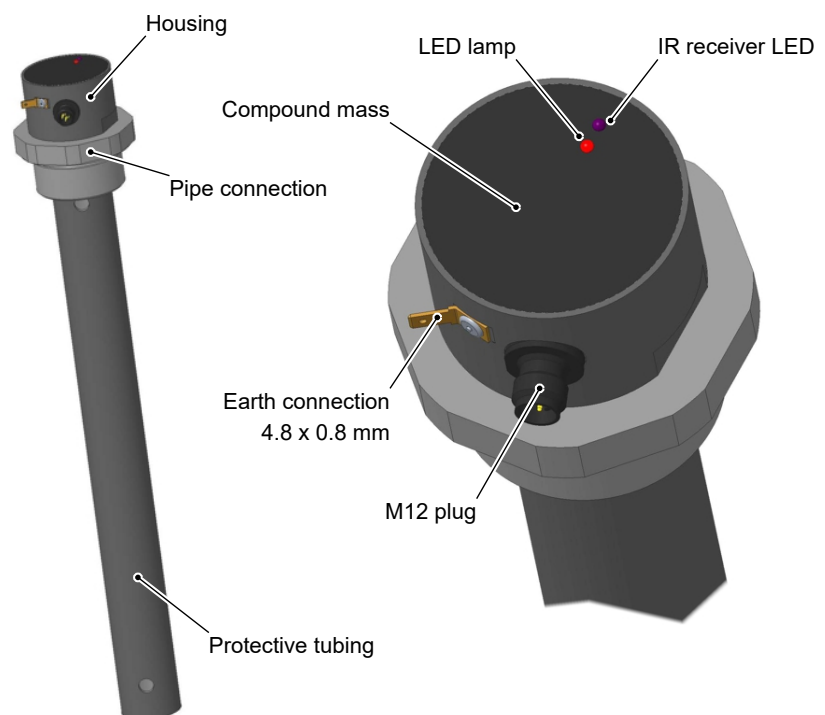

Fig. 1: Product summary

Depending on the medium, the NC56 can be supplied in various versions.

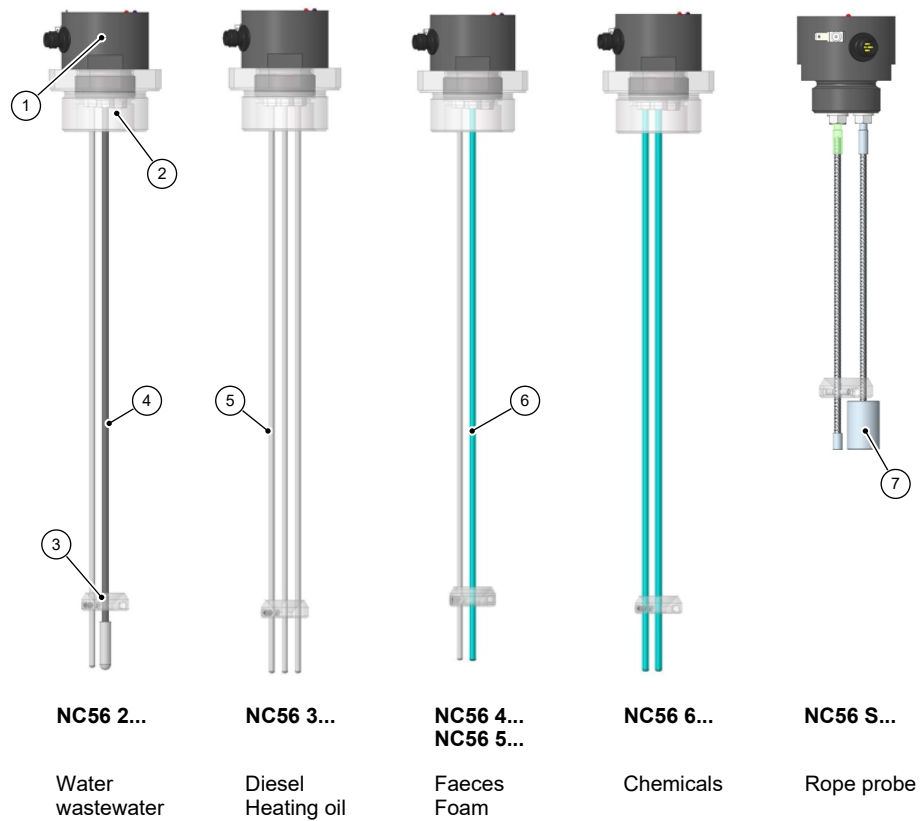

Fig. 2: Device versions

1	Probe housing	2	Pipe adapter
3	Spacer	4	Shrink-fit tubing insulation
5	Stainless steel	6	ECTFE insulation
7	Weight		

1.3 Intended use

The capacitive filling level probe NC56 serves to measure tank filling levels in tanks containing fresh water, waste water, faeces, diesel fuel, chemicals and extinguishing foam. Filling level heights of between 400 and 2000 mm can be measured. The probe can be used regardless of the tank material (metal, plastic or concrete).

Please contact the manufacturer before using this device with dirty or aggressive media because the device needs to be adapted in terms of the parts that come into contact with the media.

The device is to be exclusively used for the applications agreed between the manufacturer and the user.

1.4 Function diagram

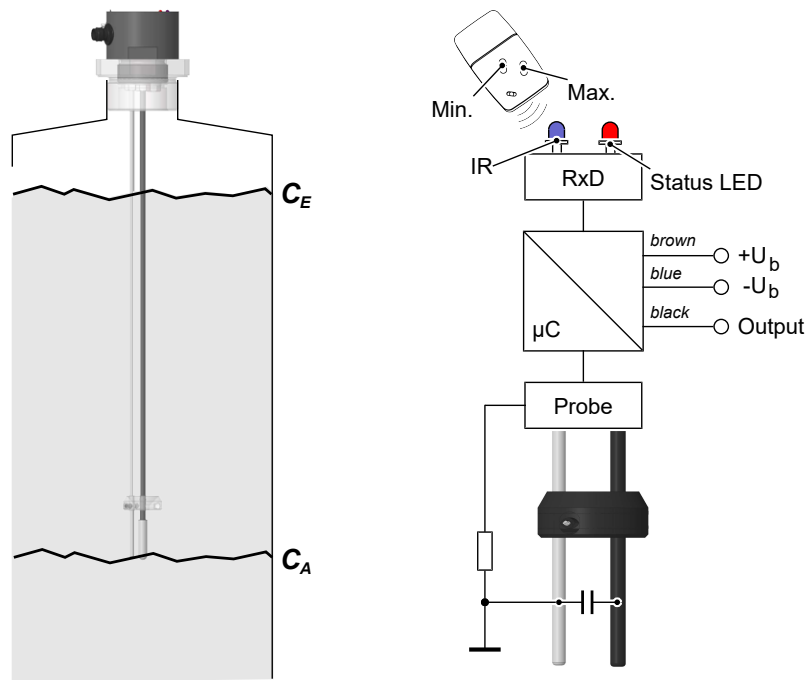

C_A : Start capacity (probe free)
 C_E : End capacity (probe covered)

Fig. 3: Function diagram

1.5 Design and mode of operation

An AC voltage signal is exerted onto two metal rods held at a defined distance to each other. This means that the metal rods become a capacitor when dipped into fluids. The capacitive values of this capacitor are primarily determined via the filling level height and the resulting change in the dielectrics.

Electronics integrated into the device convert these capacity changes into linear uniform electrical signals. A comparison is conducted with an infrared remote control.

2 Technical data

2.1 General

General information	
Type designation	NC56
Measurement principle	Continuous measurement of the capacity change between two/three probe rods, depending on the filling probe of a fluid.
Operating pressure	Max. 10 bar
Number of electrodes	2 (3 for diesel)
Thread connection	G 1¼" (for protective tubing version G2")
Protection class	IP67 as per DIN EN 60529
Reference conditions (acc. to IEC 61298-1)	
Temperature	+15 to +25 °C
Relative humidity	45 ... 75 %
Air pressure	86 to 106 kPa 860 to 1060 mbar
Installation position	vertical

2.2 Input variables

Measuring range	The measuring range lies between 400 mm and 2000 mm, depending on the ordered probe length. Other lengths available on request.
Measuring range diesel, heating oil	Due to the low conductivity of these media, the probe length should not be less than 500 mm.
Input signal	Probe rods covered: high capacity Probe rods free: low capacity

2.3 Output variables

	Current output	Voltage output
Output signal	0 to 20 mA	0 ... 10 V
	4 to 20 mA	2 ... 10 V
		0 ... 5V
		1 ... 5V
Load impedance	$(U_b - 9V)/20 \text{ mA}$	> 5 kΩ

2.4 Measuring accuracy

Measurement deviation	< 1 % FS
Temperature coefficient of the zero-point	< 0.5 % FS/10 K
Temperature coefficient of the measuring range	< 0.1 % FS/10 K

FS: Full Scale (measuring range)

2.5 Auxiliary energy

	Current output	Voltage output
Nominal voltage	24 V DC	24 V DC
Permitted op. voltage	9 to 32 V DC	12 to 32 V DC
Current draw (without signal)	30 mA	30 mA

2.6 Operating conditions

Ambient temperature range	-20 °C ... +70 °C
Storage temperature range	-40 °C ... +80 °C
Medium temperature range	Max. 80°C (with protection tube max. 60°C)
IP protection class	IP67
EMC	EN 61326-1:2013 EN 61326-2-3:2013
RoHS	EN IEC 63000:2018
e-approval	72/245/EEC
Approval number	95/54/EC E13*72/245/95/54*2182*00

2.7 Construction design

Electrical connection	M12 connector 4-pin, male
Installation position	vertical

2.7.1 Materials

Materials of the parts that come into contact with the medium	
Protection tube	PVC
Probe rod (bare)	Stainless steel 1.4404
with shrink-fit tubing	Polyolefin
with coating	ECTFE

Materials of the parts that come into contact with the surroundings	
Housing	POM-C (Polyoxymethylene (copolymer))
Compound mass	Polyurethane
Spacer	POM-C (Polyoxymethylene (copolymer))
M12 plug	Polyamide
Earthing connection	Brass, tin-coated

2.7.2 Dimension drawings

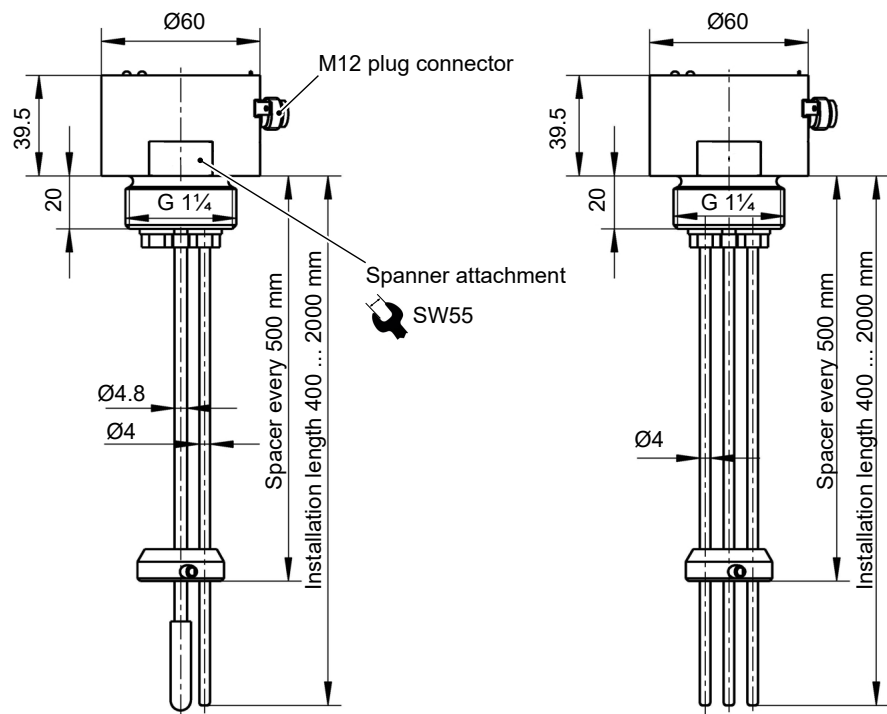

Probe with shrink-fit tubing

**Probe with 3 rods
(uncoated)**

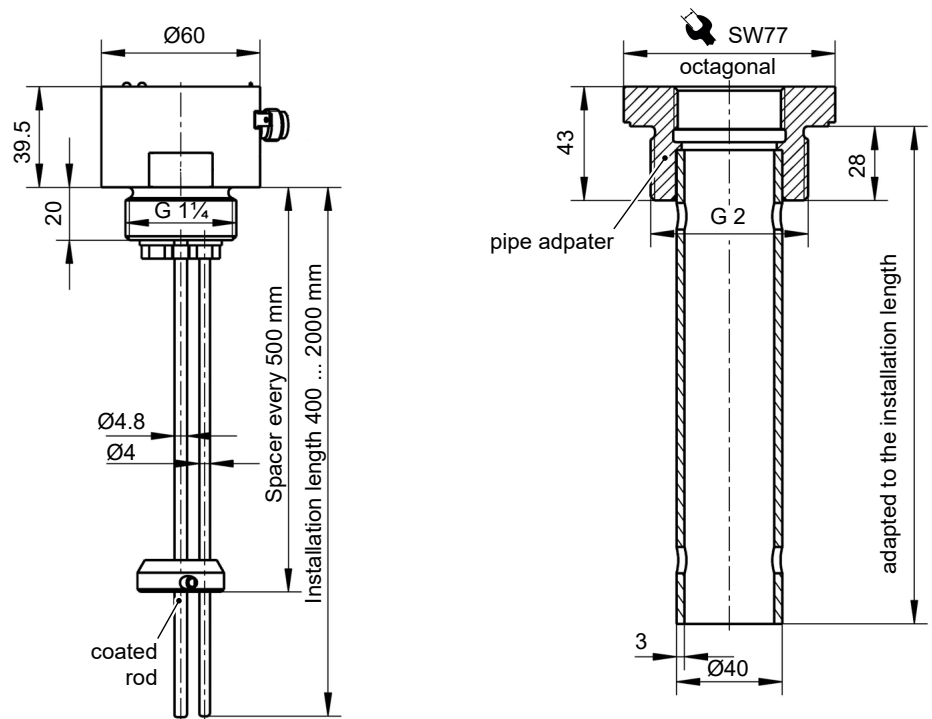

**Probe with
coated rod**

Protective tubing

Fig. 4: Dimension drawing

3 Order codes

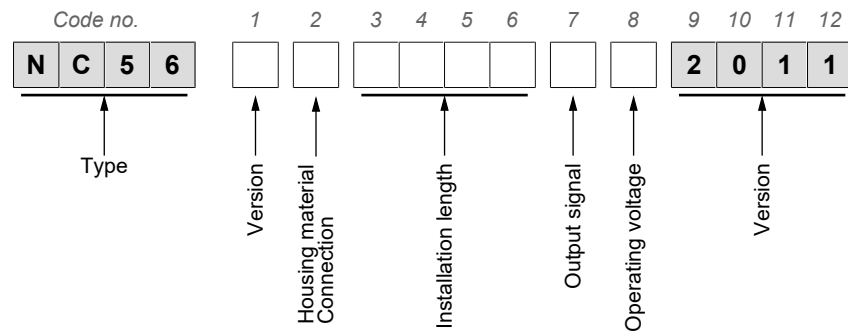

Design:

[1]	(Code no.)	Rod 1	Rod 2	Rod 3
2	Water waste water	Shrink-fit tubing	Bare (1.4404)	---
3	Diesel	Bare (1.4404)	Bare (1.4404)	Bare (1.4404)
4	Faeces	ECTFE coating	Bare (1.4404)	---
5	Extinguishing foam agent	ECTFE coating	Bare (1.4404)	---
S	Cable probe	Steel cable (1.4404)	Steel cable (1.4404)	---
6	Chemicals	ECTFE coating	ECTFE coating	---

Casing material/connection:

[2]	(Code no.)
0	Plastic casing with size 1¼ for outside use incl. size 2 protection tube
P	For outside use incl. size 2 protection tube
G	For outside use and bores for suction vehicles (only for model 4 - Faeces)

Installation length (from sealing surface):

[3-6]	(Code no.)
0400	400 mm
	to
2000	2000 mm
	<i>The probe rods are produced in steps of 50 mm.</i>

Output signal:

[7]	(Code no.)
A	0 to 20 mA
P	4 to 20 mA
C	0 to 10 V
Z	2 to 10 V
U	0 to 5 V
D	1 to 5 V

Operating voltage:

[8]	(Code no.)
E	9 to 32 V (for current output)
F	12 to 32 V (for voltage output)

Version:

[9-12]	(Code no.)
2011	Version

3.1 Accessories

Order no.	Designation	No. of poles	Length
06401993	Connection cable with M12 connector	4 poles	2 m
06401994	Connection cable with M12 connector	4 poles	5 m
06401563	Connection cable with M12 connector	4 poles	7 m
06401572	Connection cable with M12 connector	4 poles	10 m

Infrared remote control

Order no.	Designation
EU04	Infrared remote control

3.2 Information about the document

This document contains all technical data about the device. Great care was taken when compiling the texts and illustrations. nevertheless, errors cannot be ruled out.

Subject to technical amendments.

Notes

Notes



FISCHER Mess- und Regeltechnik GmbH

Bielefelder Str. 37a
D-32107 Bad Salzuflen

Tel. +49 5222 974-0

Fax +49 5222 7170

www.fischermesstechnik.de
info@fischermesstechnik.de