

Mark 575 Series

Self-Operated Back Pressure Regulators

The Mark 575 Wafer Style Sliding Gate Back Pressure Regulator is used to regulate upstream pressure at a predetermined setpoint. The spring in the Mark 575 holds the sliding gate seats in their normally closed position.

The upstream pressure is sensed beneath the diaphragm. As the upstream pressure exceeds the setpoint, pressure is exerted on the diaphragm which raises the stem to modulate the disc (the movable component of the sliding gate seat set) toward the open position. As the seats open, upstream pressure will be regulated to the required setpoint. A decrease in pressure allows the spring and diaphragm to move the seats toward the closed position.



MARK 575 FEATURES

- **Wafer Style Body** — reduces weight
- **High Capacity** — 6" (DN150) provides 400 Cv (345Kv)
- **No Sensing Line Required**
- **Sliding Gate Trim** — unique seat design for unsurpassed trim life and accuracy.
- **Jorcote Seat Coating** — ceramic composite for liquids, gases and especially steam. Very low friction with outstanding wear resistance and a temperature rating of up to 550°F (288°C). Steam tested to 1,000,000 cycles and still maintained Class IV leakage.
- **Jorlon Diaphragm** — extremely durable, virtually universally applicable up to 450°F. Tested without failure to over 1,000,000 full stroke cycles. Ideal for steam, gases and liquids. 316SST diaphragm applicable up to 550°F.
- **Straight-through Flow** — The flow is straight through the valve seats and body. Direction of the disc travel is perpendicular to the flow, not opposed to the direction of the flow. Thus, the flow does not unbalance the seats. The MK575 can use a wider range of its stroke to give accurate control; less offset and rangeability up to 20:1.
- **Quiet Operation** — typically 5-10 dB less than conventional globe style regulators. The disc and plate are always in contact, which eliminates chattering. Straight-through flow minimizes turbulence. Multiple orifices in the plate and disc divide the flow stream into smaller flow components.
- **Minimum Maintenance** — The MK575 sliding gate seats require no special tools for disassembly. The seats are pre-lapped at the factory and are self-lapping while in operation ensuring a continual tight shutoff.



Jordan Valve, a division of Richards Industries
3170 Wasson Road • Cincinnati, OH 45209
513.533.5600 • 800.543.7311 • 513.871.0105 (f)
info@richardsind.com • www.jordanvalve.com

MARK 575 SERIES - SUPERIOR ON STEAM APPLICATIONS, IDEAL FOR GAS AND LIQUIDS

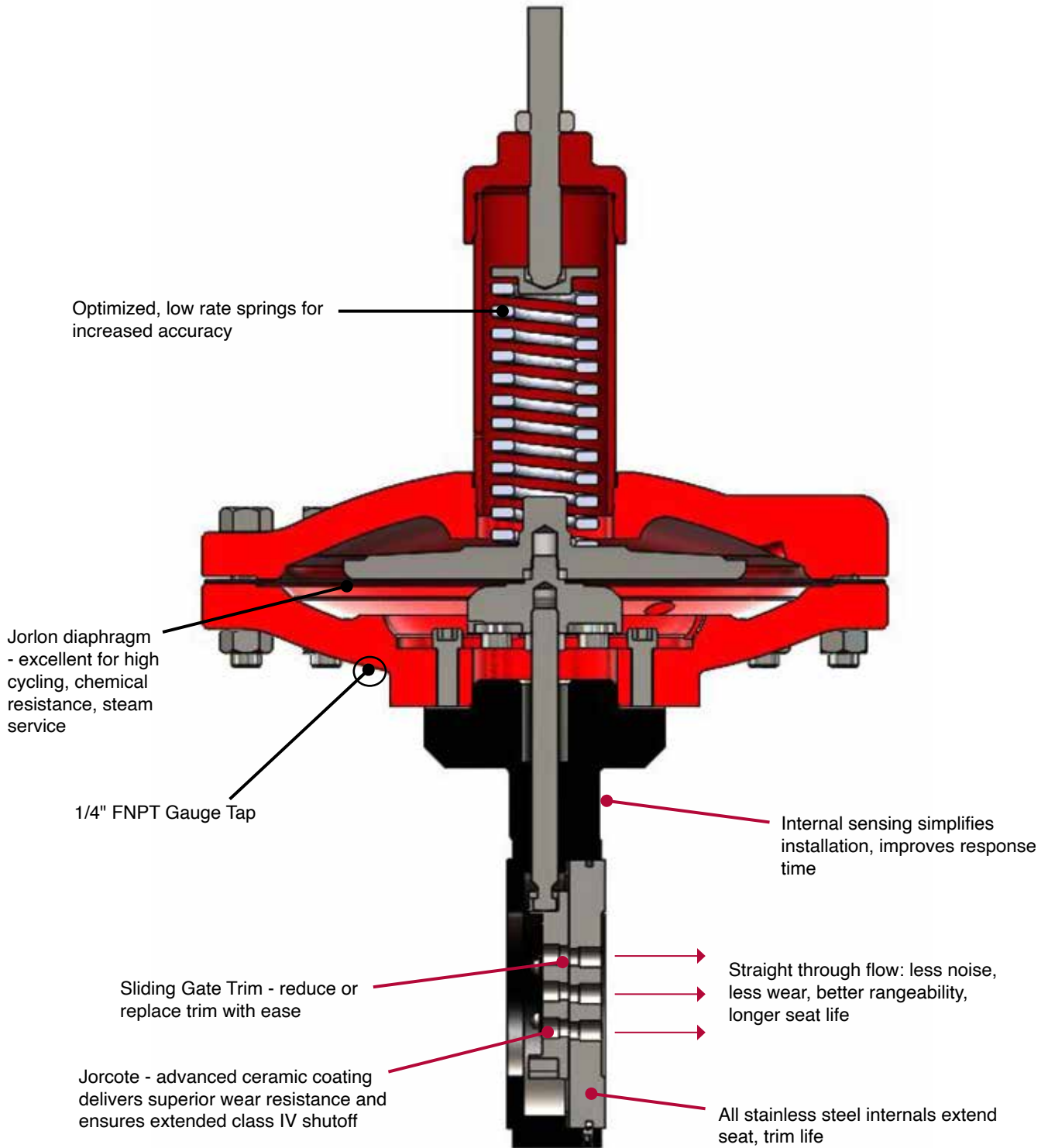

SPECIFICATIONS

Sizes: 3" (DN80) through 6" (DN150)
ANSI 150# / 300# (PN25/40) Class Wafer Style
Valves (bolt-around)

Body Materials:

- Carbon Bar (A105)
- Carbon Steel (WCB)
- Stainless Steel (CF8M)
- Stainless Steel Bar (SA-479)
- Others on application – Consult Factory

Body Seals

- Jorlon Body Gasket
- Fiber Gasket for Body/Bonnet

Diaphragm

- Jorlon
- EPDM
- Neoprene/Nylon
- Viton
- Buna-N
- Others on application – Consult Factory

Trim

- 316SS/TFE
- Monel/TFE
- Alloy 20/TFE
- Hastelloy C/TFE
- Others on application – Consult Factory

Seats: 316SS/Jorcote; Others on application – Consult
Factory

Pressure Ranges:

- 4-15psi (0,28-1,03bar)
- 7-24psi (0,48-1,65bar)
- 16-30psi (1,10-2,07bar)

Max Delta P: 50 psi

Cv (Kv):

- 9.5 (8,2)
- 33 (28)
- 38 (33)
- 72 (62)
- 76 (66)
- 103 (89)
- 180 (155)
- 400 (345)

Shutoff: ANSI Class IV

Options:

- Handwheel- In Range
- Stainless Bolting
- Clean for Oxygen Service
- Clean for Oil Free Service

PRESSURE/TEMPERATURE CHART

Carbon and Stainless 300#

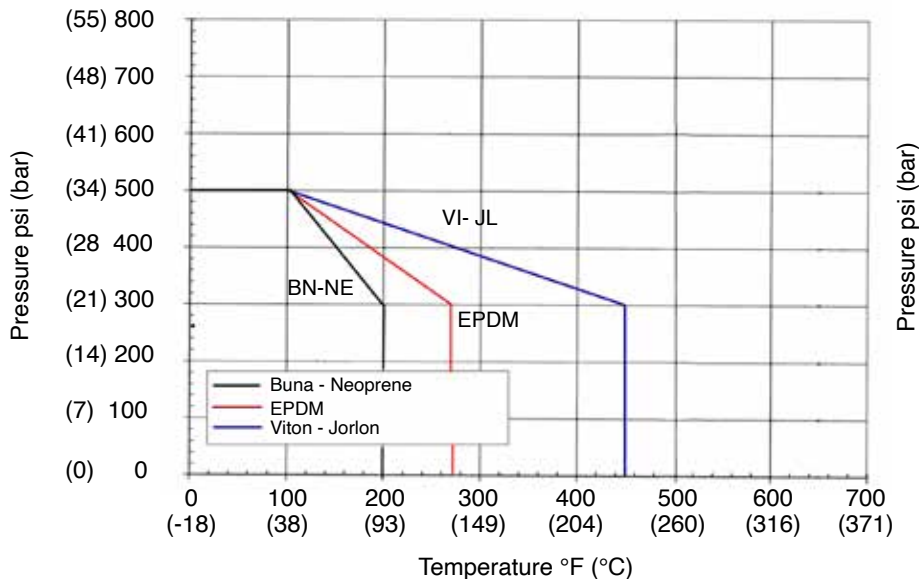

SLIDING GATE FEATURES & BENEFITS

Jordan Valve's Sliding Gate Seats

Installed in the widest range of gas, chemical and steam applications the world over, our pressure regulators, temperature regulators and control valves have been providing the following benefits for over fifty years.

Shorter stroke length than globe or cage designs

- Provides faster response to input signal changes
- Significantly extends packing and diaphragm life
- Allows for more compact valve/actuator assembly

Straight-through flow

- Significantly reduces turbulence, thereby reducing noise and erosion
- Markedly increases rangeability associated with "flow to open" and "flow to close" designs
- Eliminate valve "chatter" commonly observed when valve is partially open

Ease of maintenance

- During seat/Cv change (seats are not screwed or pressed in body)
- Attributable to lightweight, compact design
- Fewer trim components

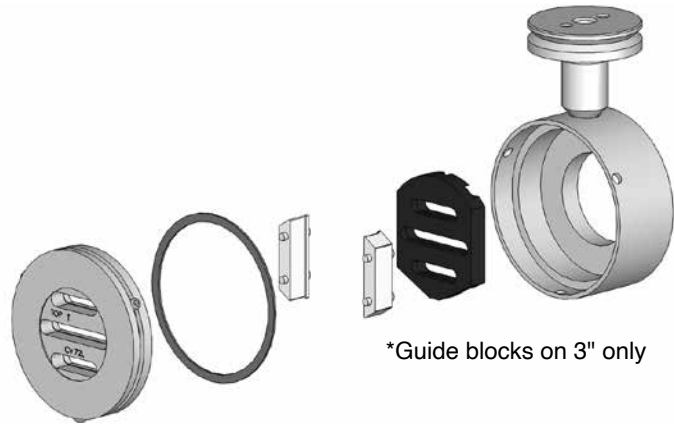

Features

- Easy installation between flanges with wafer body
- High flow rates
- Self cleaning, self lapping seats
- Reduced noise compared to conventional globe/cage valves
- More resistant to cavitation / flashing with straight through, wafer design

DIMENSIONS – MK575

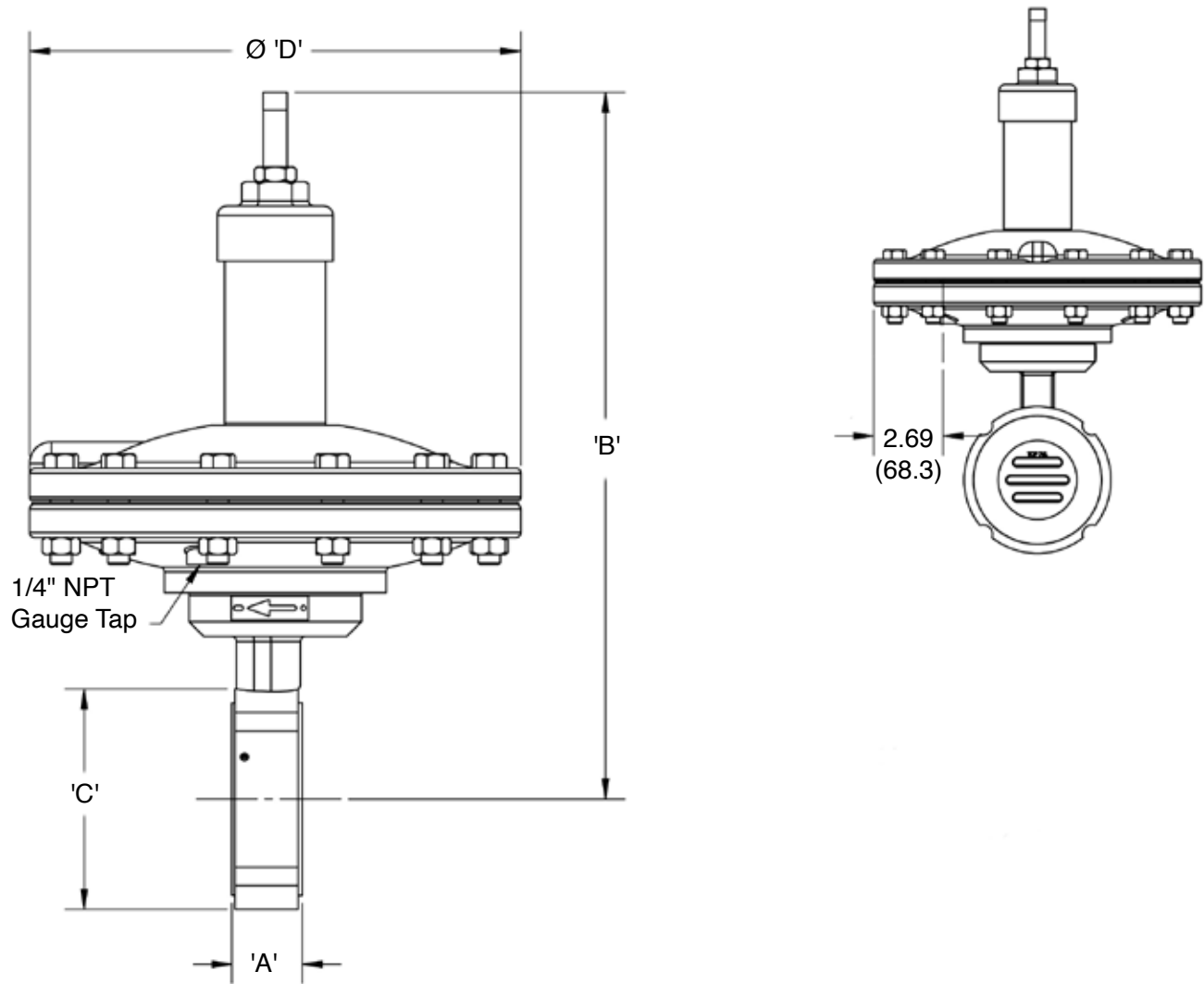

INCHES

Size	A	B	C	D	Weight
3"	1.81	18.5	5.25	12.75	90 lbs
4"	2.06	19.6	6.46	12.75	110 lbs
6"	2.23	20.6	8.62	12.75	113 lbs

METRIC (MM)

Size	A	B	C	D	Weight
DN80	46.0	469.9	133.4	323.4	41 kg
DN100	52.3	497.8	164.1	323.9	50 kg
DN150	56.6	523.2	218.9	323.9	51 kg

ORDERING SCHEMATIC MK575

Model No	Size	Body Mat'l	1	2	3	4	5	6	7	8	9	10	11	12	13	14	15	16

Model	
575	Wafer Style

Size	
300	3"
400	4"
600	6"

Body Material	
CB	Carbon Bar (A105)
SB	Stainless Steel Bar (SA-479)
CS	Carbon Steel (WCB)
S6	Stainless Steel (CF8M)

End Connections	
I3	150# / 300# IFE
C5	6" 150 Bolt thru CS/S6 Only
C3	6" 300 Bolt thru CS/S6 Only
ZZ	Non-Standard

Trim	
MN	Monel / TFE
A2	Alloy 20 / TFE
HC	Hastelloy C / TFE
T6	316SS / TFE
ZZ	Non-Standard

Seats			
5 & 6	Material	Cv	
		W	316SS / Jorcote
		A	33
		B	38
		E	72
		F	76
		H	103
		I	180
		J	400
ZZ	Non-Standard		

Ranges	
22	4-15
30	7-24
52	16-30
ZZ	Non-Standard

Diaphragm	
JL	Jorlon
NN	Neoprene / Nylon
VI	Viton
BN	Buna-N
ZZ	Non-Standard

Actuator (Diaph. mat'l ref.)	
ED	Standard - Elastomer Diaphragms
ZZ	Non-Standard

Double Bolting Option			
Accessories		End Conn. Option	Actuator Option
00	None		
ZZ	Non-Standard		

Accessories	
0	None
5	I8-8SS Bolting
6	316SS Bolting
8	Oxygen Clean
9	Oil-Free Clean
Z	Non-Standard

PED Compliance	
0	Not Required
F	PED Category 1
Z	Non-Standard

